

KETTLES

Electric, Tilting, Cabinet Base

MODELS: EMT-6-6 (Unit has 1 – 6 Gallon Kettle)
EMT-6-10 (Unit has 1 – 6 Gallon and 1 – 10 Gallon Kettle)

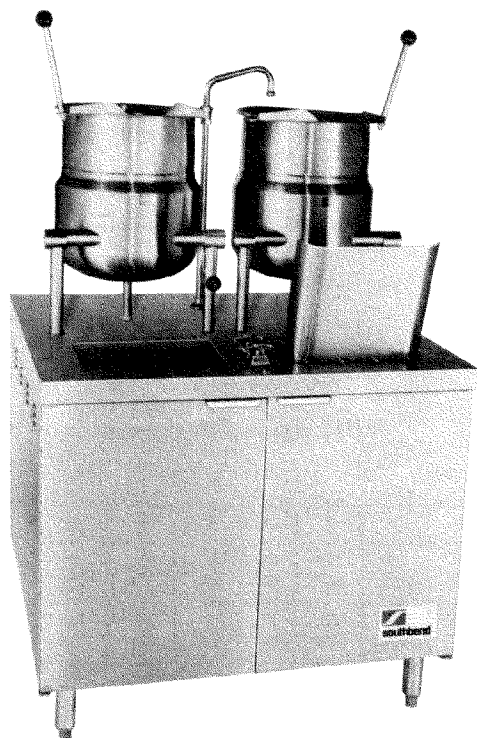

Southbend Kettles offer unsurpassed versatility . . . rugged, dependable and are the most durable you can buy . . . up to 25% heavier than other competitive models, as proven by a comparison of shipping weights.

Assembly Structure

Each unit has two 6 gallon or one 6 gallon and one 10 gallon stainless steel steam jacketed trunnion kettles. They are mounted on a 32" high cabinet base. Hot and cold water fill faucet, 5" deep sink and drain and steam control valves are located on kettle leg. A removable splash guard grate is standard with unit.

Kettle

Direct connected, electric, tilting. A double wall kettle interior forms a steam jacket around lower 2/3 of kettle. Bottom of kettle is of elliptical design for superior heat circulation. Tubular stainless steel mounting frame has steam supply and condensate return pipes completely concealed within frame members. The sealed stainless steel tilt mechanism bearings permit kettle to tilt forward 90° for complete emptying and return to vertical when handle is released. A removable operating handle with heatproof knob is mounted on the left or right. Models have a single support leg with flush-inserted nylon foot.

Cabinet Base

Kettles are mounted on a cabinet base with full perimeter angle frame, reinforced counter and boiler mountings, electric boiler with controls, all stainless steel exterior, hinged doors with magnetic latches and 6" (152mm) stainless steel legs with adjustable bullet feet.

Model EMT-6-6 (36" Base)

OPERATION:

Electric heated steam boiler operating at 15 psi (1 kg/cm²) and rated at:
 24 KW standard

The steam boiler shall be equipped for operation on:

- 208 VAC, 3 Phase, 60 Hz
- 240 VAC, 3 Phase, 60 Hz
- 380 VAC, 3 Phase, 50 Hz (Optional at Extra Cost)
- 415 VAC, 3 Phase, 50 Hz (Optional at Extra Cost)
- 480 VAC, 3 Phase, 60 Hz (Optional at Extra Cost)

The controls shall be equipped for operation on:

- 115 VAC, 1 Phase, 60 Hz

OPTIONS:

- Lift off stainless steel cover for kettle
- Lift out stainless steel wire basket strainer
- Automatic boiler blowdown
- 30.0 KW Boiler
- 42.0 KW Boiler

■ INQUIRE TO FACTORY FOR SPECIAL OR CUSTOM REQUIREMENTS.

Boiler Blowdown Option

Boiler empties under pressure (blows down) automatically upon each shut down and will automatically fill with water on start up. Natural gas or propane gas.

Technical Data

Unit dimensions, utility information, construction specifications and miscellaneous information is listed on the reverse side.

Warranty

One year Parts and Labor Warranty at no extra charge from the date of purchase.



We reserve the right to change specifications and product design without notice. Such revisions do not entitle the buyer to corresponding changes, improvements, additions or replacements for previously purchased equipment. Southbend has a policy of continuous product research and improvement.

MODEL:

EMT-6-6 EMT-6-10

Not for Scale
For Dimensional Purposes Only.

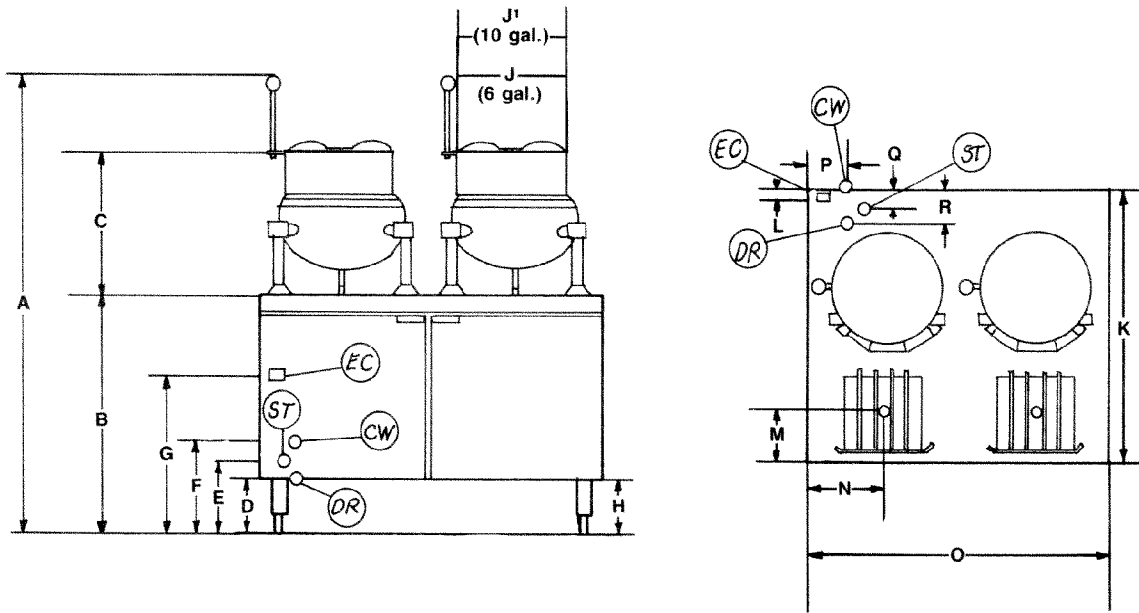

Specifications are subject to change without notice.

NOTE: Splash guard grates not shown on front view.

DIMENSIONS:

() = Millimeters

MODEL	A	B	C	D	E	F	G	H	J	J'	K	L	M	N	O	P	Q	R
EMT-6-6	55" (1397)	32" (813)	19 3/8" (492)	6" (152)	7" (178)	8" (203)	22" (559)	6" (152)	12" (305)	16" (406)	33" (838)	2" (51)	9" (229)	9" (229)	36" (914)	6" (152)	4" (102)	7" (178)
EMT-6-10	55" (1397)	32" (813)	19 3/8" (492)	6" (152)	7" (178)	8" (203)	22" (559)	6" (152)	12" (305)	16" (406)	33" (838)	2" (51)	9" (229)	9" (229)	36" (914)	6" (152)	4" (102)	7" (178)

SERVICE CONNECTIONS

CW Cold Water: 1/2" (13 mm) nominal tubing for cold water to kettle fill faucet.

DR Drain: 2" (51 mm) IPS piped to open floor drain. No solid connection.

EC Electric Connection: 1/2" (13 mm) conduit connection to controls. 2 amps per compartment, 120-60-1 or 220-50-1.

ST Steam Take-off Connection: 3/4" (19 mm) optional to operate adjacent equipment.

* Pressure reducing valve is required if incoming pressures exceeds 50 PSI (3.4 kg/cm²).

INSTALLATION

For installation on combustible floors (with 6" legs) and adjacent to combustible walls, allow 6" (15 cm) clearance.

NOTE: Before connecting water to this unit, have water supply analyzed to make sure hardness is no greater than 2.0 grains and pH no greater than 7.5. Water which fails to meet these standards should be treated by installation of a water conditioner. EQUIPMENT FAILURE CAUSED BY INADEQUATE WATER QUALITY IS NOT COVERED UNDER WARRANTY.



A MIDDLEBY COMPANY