

Temperature Control with Harness Kit (00-913149) Installation Instructions

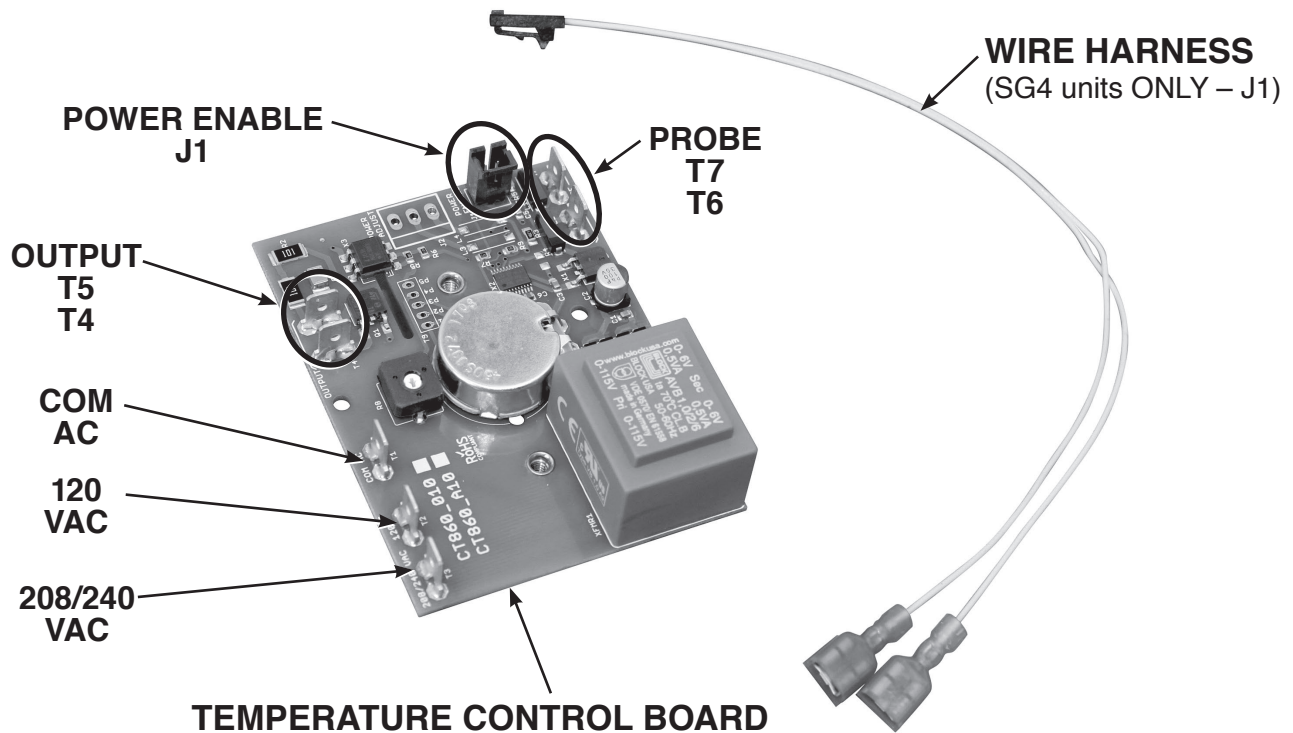

WARNING Disconnect the electrical power to the machine and follow lockout/tagout procedures

- Temperature control board manufacturer has been changed from Fast for better performance.
- Kit includes Temperature Control Board (1), Wire Harness (SG4 units only) (1), and Instructions.
- This kit is replacement of 353613-2 and 428897-8 boards.



Removal of Fast Temperature Boards

1. Remove wires from Fast Temperature Control Board.
2. Remove Fast Temperature Control Board and discard.

Installation of new Temperature Control Board

1. Install Temperature Control Board.
2. Connect wires.

NOTE: Install wiring harness on SG4 units ONLY (J1).

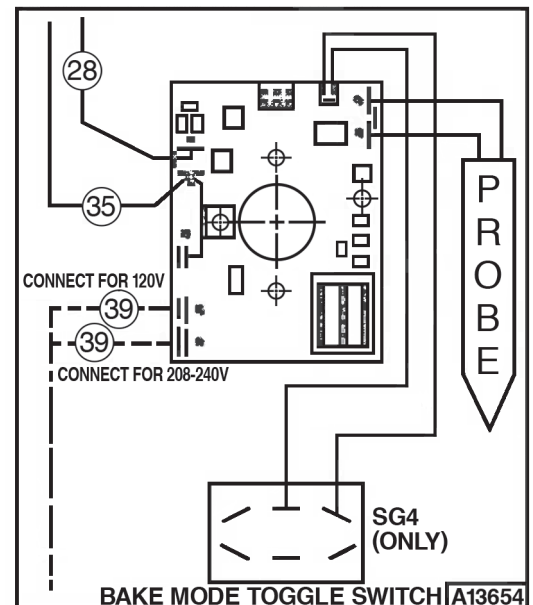

Wiring Diagram

*OEM number used for reference only.