

## Tiger XL Cool Froth™ Espresso Machine

ITEM#

PROJECT

DATE



**Model Tiger XL Cool Froth with milk drawer**

Dimensions: 25.5"H x 15.8"W x 18.1"D  
(64.8 cm H x 40.1 cm W x 45.9 cm D)



**Model Tiger XL Cool Froth EXT external milk**

Dimensions: 19.3"H x 15.8"W x 18.1"D  
(49 cm H x 40.1 cm W x 45.9 cm D)

### Features

#### BUNN Espresso® Tiger XL Cool Froth Series

*Simple solution for exceptional espresso beverages from a sleek, compact super-automatic*

- Up to 180 shots per hour from less than 16" of counter space.
- Your choice of four drink selections: espresso, cappuccino, latte and iced cappuccino.
- Intelligent modular brewing chamber adjusts espresso.
- Simulates Barista tamping and polishing motion to provide uniform extraction.
- Two-grinder model for two varieties of espresso beans.
- Hoppers hold 1.75 lbs of fresh beans.
- Adjusts for 4.5 to 7.4 inch cup clearance.
- Pod brewing option standard on all models.
- Intuitive operational design. Easy to use control pad guides user through steps for making drinks.
- Easy daily cleaning.
- Innovative milk delivery system does not inject steam or water to dilute the foam so customers enjoy a full, rich flavor experience.
- Available with a self-contained 1 gallon milk drawer or external milk.

For current specification sheets and other information, go to [www.bunn.com](http://www.bunn.com).

### Related Products

#### Espresso Water Quality System

EQHP-ESP  
Product No.: 39000.0008



#### Replacement Cartridge

EQHP-ESPCRTG  
Product No.: 39000.1008

#### Cafiza™ Cleaning Tablets

Product No.: 36000.1189 (100 count)  
Product No.: 36000.1188 (12/case)



#### Cup Heater

Product No.: 35800.0400



#### Rinza™

Milk Frother Cleaner  
Product No.: 39265.0000 (each)  
Product No.: 39265.0001 (6/case)



#### Steamer

Product No.: 35800.0401



#### Complete Cafe™

Sanitizer  
Product No.: 39265.0010 (each)  
Product No.: 39265.0011 (6/case)



#### Model

Tiger XL  
Tiger XL, EXT

#### Agency Listing



## Dimensions & Specifications

Model	Product #	Volts	Amps	Tank Heater Watts	Total Watts	Capacity	Cubic Measure	Shipping Weight	Cord Attached
Tiger XL	35800.0008	120	16	1700	1850	180 shots/hr	12.5 ft <sup>3</sup>	103 lbs	Yes/20A Plug
	35800.0009	208	12	2000	2400	180 shots/hr	12.5 ft <sup>3</sup> (.35 m <sup>3</sup> )	103 lbs (46.7 kg)	Yes/No Plug
Tiger XL, EXT	35800.0010	120	16	1700	1850	180 shots/hr	10.5 ft <sup>3</sup>	88 lbs	Yes/20A Plug
	35800.0011	208	12	2000	2400	180 shots/hr	10.5 ft <sup>3</sup> (.30 m <sup>3</sup> )	88 lbs (39.9 kg)	Yes/No Plug

**Capacity per Hour:** Espresso: 180  
 Cappucino: 120  
 Cold Cappucino: 100  
 Cafe Latte: 100  
 POD Products: 60  
 Hot Water: 7.9 gallons (30 litres)

Model includes: Machine, water filtration system, installation and 2-year preventative maintenance.

Electrical: Model requires 2-wire grounded service rated 120/208V, single phase, 50/60 Hz.

Plumbing: 20-100 psi (138 - 690 kPa). Machine supplied with 1/4" male flare fitting. All machines are supplied with a waste water hose and must be connected to a drain.

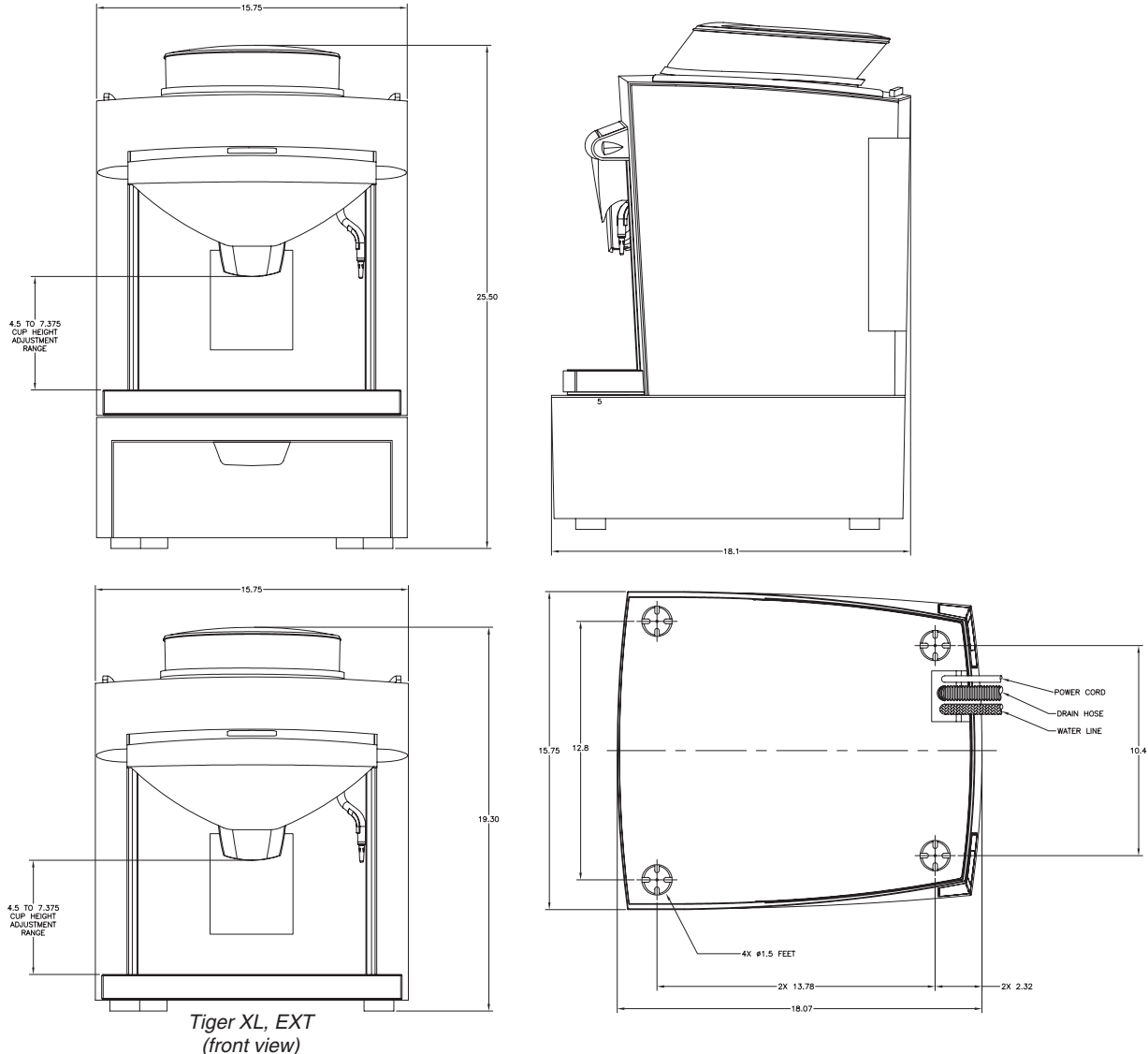

Bunn-O-Matic® Corporation - 1400 Stevenson Drive Springfield, Illinois 62703 • 800-637-8606 • 217-529-6601 • Fax 217-529-6644 • www.bunn.com

BUNN® practices continuous product research and improvement. We reserve the right to change specifications and product design without notice. Such revisions do not entitle the buyer to corresponding changes, improvements, additions or replacements for previously purchased equipment.

All dimensions shown in inches.

8/08 © Bunn-O-Matic Corporation