



BEVERAGE-AIR

3779 Champion Blvd., Winston-Salem, NC 27105
1-888-845-9800 Fax# 1-336-245-6453
<http://www.Beverage-Air.com>

Commercial Refrigeration Equipment General Specification

CT96 SERIES—COUNTERTOP REFRIGERATOR

Select from solid end or glass end models. Used for merchandising and storage of product. Requires minimum countertop space.

CABINET CONSTRUCTION

Heavy duty construction includes white epoxy coated steel interior walls. Exterior finish is heavy duty steel with a baked on durable paint. Choose from black, white or stainless steel finish. Door frames are constructed of anodized aluminum.

2" foamed-in-place CFC free polyurethane insulation enhances the structural strength of the cabinet and helps increase energy efficiency.

Triple pane glass door features inside and outside panes that are tempered for added safety.

Glass end model features one glass panel per side for enhanced product display.

Three white epoxy coated steel shelves are standard. Only top 2 shelves are adjustable.

REFRIGERATION

Refrigeration system uses R134a refrigerant, which is CFC free for compliance with environmental safety concerns. Operating temperatures from 35°F to 41°F.

ELECTRICAL

Interior fluorescent lighting enhances product illumination. Units wired at factory and ready for connection to a 115/60/1 phase, 15 amp dedicated outlet. 8' long cord and plug set included.

SPECIAL FEATURES

- Optional stand and casters available

ELECTRICAL CONNECTION

Units pre-wired at factory and include 8' long cord and plug set.



115/60/1
NEMA-5-15P

Item No. _____
Quantity _____

COUNTERTOP MERCHANDISER SERIES CT96 SERIES

MODELS:
CT96Y
CT96GEY



CT96Y



CT96GEY

Available From:



*Note: Not all markings may apply to all model variations.

Model Specified _____	Store# _____
Location _____	Quantity _____



BEVERAGE-AIR

PLAN VIEWS

Countertop Merchandiser Series

Model: CT96Y, CT96GEY

MODEL	CT96Y	CT96GEY
EXTERNAL DIMENSIONAL DATA		
Length Overall (inches)	20 7/8"	20 7/8"
Length Overall (mm)	530	530
Depth Overall (inches)	25 1/2"	25 1/2"
Depth Overall (mm)	648	648
Height Overall— (inches)	37 1/2"	37 1/2"
Height Overall— (mm)	953	953
Number of doors	1	1
Depth with Door Open 90 °	45 1/8"	45 1/8"
Clear Door Opening (inches)	18 1/4" x 34 3/4"	18 1/4" x 34
INTERNAL DIMENSIONAL DATA		
NET Capacity (cubic ft.)	6.8	6.8
NET Capacity (Liters)	193	193
Internal Length Overall (inches)	18 1/4"	18 1/4"
Internal Length Overall (mm)	464	464
Internal Depth Overall (inches)	18 1/2"	18 1/2"
Internal Depth Overall (mm)	470	470
Internal Height Overall—(inches)	30 1/2"	30 1/2"
Internal Height Overall—(mm)	775	775
Number of shelves	3	3
ELECTRICAL DATA		
Full Load Amperes 115/60/1	3.6	3.6
ENERGY CONSUMPTION (KWH)		
	2.87	2.87
REFRIGERATION DATA		
Horsepower	1/5	1/5
WEIGHT DATA		
Gross Weight (Crated lbs)	175	175
Gross Weight (Crated kg)	79	79

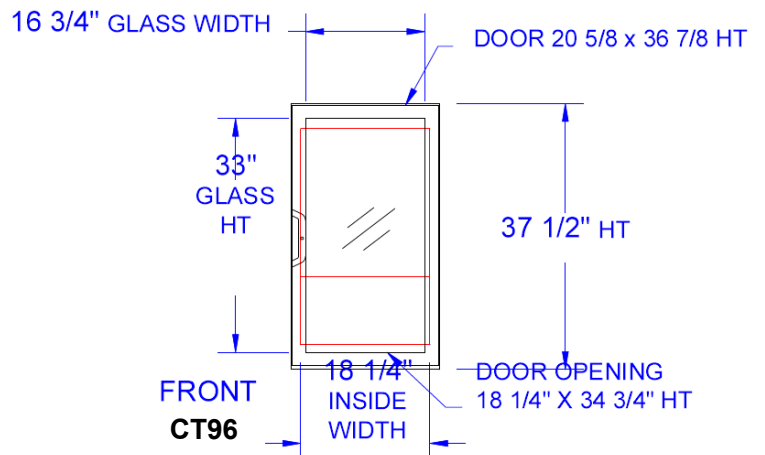
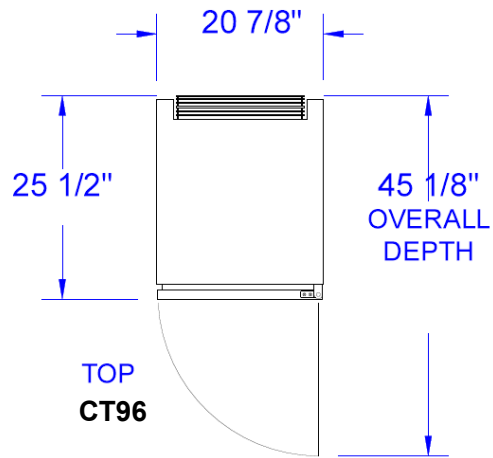
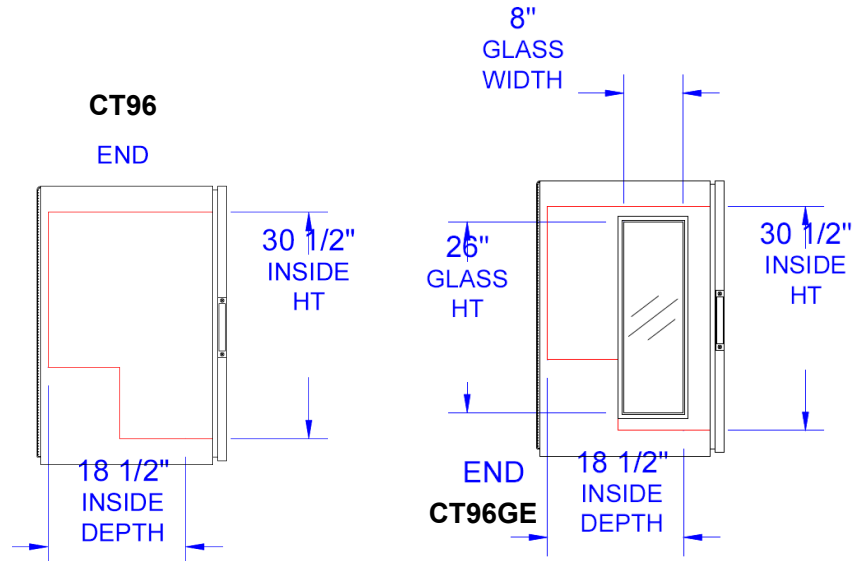

Note: Not all markings may apply to all model variations.

BEVERAGE-AIR® CORPORATION

3779 Champion Blvd. • Winston-Salem, NC 27105 USA • (336) 245-6400 • Fax (336) 245-6453 • (888) 845-9800 • www.beverage-air.com

Specifications are subject to change without prior notice. 06/10

Tundra Specialties