

Imperial Turbo Flow Gas Convection Ovens



Model ICVG-1 Gas
Single Deck,
Standard Depth



Model ICVG-1 Shown with
optional s/s shelf and
adjustable rack supports



Model ICVD-2 Gas
Double Deck, Bakery Depth

Single Deck Models

- ICVG-1 Standard Depth
- ICVD-1 Bakery Depth

Double Deck Models

- ICVG-2 Standard Depth
- ICVD-2 Bakery Depth

Imperial Turbo Flow Convection Ovens

- Stainless steel exterior: doors, front, sides, legs and top.
- 70,000 BTU/hr. (21 KW) oven for Standard depth ICVG series.
80,000 BTU/hr. (23 KW) Bakery depth ICVD series provides high production cooking and fast recovery.
- Rugged 1/2 h.p. – two speed motor for high volume or delicate baking.
- Manual controls and programmable control option available on all models.
- Large window and two interior lights for easy viewing of products being cooked.
- Single handle simultaneously opens both doors.
- Heavy duty 60/40 stainless steel doors.
- Double bearings on the top and bottom of each door. Four bearings per door extend the life of the door mechanism and eliminates side-to-side shaft movement to improve door pressure locking.
- Door chassis is designed to endure constant opening and closing. Handle is secured to a 10 gauge stainless steel door chassis, not to the door cover. Chassis transfers the force of the doors constant opening and closing to the rugged door shaft. System is located on the top and bottom of both doors.
- Model ICVG-1 includes stainless steel legs as standard. Stainless steel shelf and adjustable rack supports are optional.
- One year parts and labor warranty.
- AGA and CGA design certified, NSF and CE listed.



Turbo-Flow provides even heat
throughout the oven

Imperial Commercial Cooking Equipment

1128 Sherborn Street ■ Corona, CA 92879 ■ 800.343.7790 ■ Ph: 951.281.1830 ■ Fx: 951.281.1879
www.imperialrange.com ■ E-mail: imperialsales@imperialrange.com

Imperial Turbo Flow Gas Convection Ovens

Specification #:

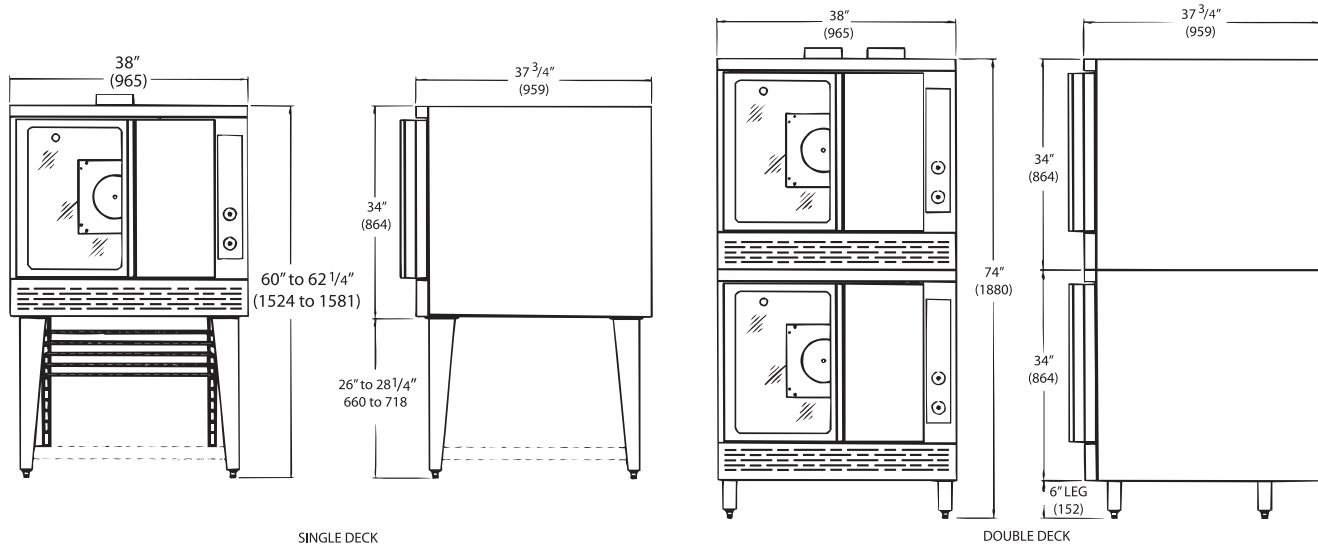

Turbo-Flow Convection Ovens

Model #	Description	Overall Dimensions			Total BTU	Total (KW)	Ship Weight	
		Width	Height	Depth			(Kg.)	Lbs.
Gas								
ICVG-1	Gas Single Deck, Standard Depth	38" (965)	60" (1524)	40 ¹ / ₄ " (1022)	70,000	(21)	(236)	521
ICVG-2	Gas Double Deck, Standard Depth	38" (965)	74" (1880)	40 ¹ / ₄ " (1022)	140,000	(41)	(455)	1005
ICVD-1	Gas Deck, Bakery Depth	38" (965)	60" (1524)	44 ¹ / ₄ " (1124)	80,000	(23)	(277)	611
ICVD-2	Gas Double Deck, Bakery Depth	38" (965)	74" (1880)	44 ¹ / ₄ " (1124)	160,000	(47)	(536)	1185

Note: For Cook and Hold computer control feature add the suffix "- H" for one oven or "- HH" if required for both ovens.

Crated Dimensions: Add 2" (51) to width; 7" (178) to depth; and 3" (76) to oven cabinet height.

Standard Exterior Specifications

Front, sides, doors, legs and top shall be stainless steel with welded and finished stainless steel seams. Rigid stainless steel legs shall have an easy-to-assemble mounting plate.

Oven shall have 1/2 HP, 1725 RPM blower motor (120VAC-60 HZ - 1Ph) 5 amp draw. Unit shall be provided with 3-prong 6" (1829mm) power cord. Unit shall include five heavy duty chrome plated racks supported by 12 position chrome plated guides. Unit shall have a three-position switch for cooking or cool down; burner "on" indicator light; and one hour manual timer or optional programmable timer.

Thermostat shall be adjustable from 150°F to 500°F. (66°C to 260°C).

ICVG interior cavity dimensions shall be 29" w x 24" d x 24" h (737 x 610 x 610). ICVD interior cavity dimensions shall be 29" w x 28" d x 24" h (737 x 711 x 610).

Gas Requirements:

Manifold pressure: 5.0" W.C. Natural Gas
10.0" W.C. Propane Gas

Manifold size: 3/4" NPT

Input rating: 70,000 BTU/hr (21 KW) per oven ICV
80,000 BTU/hr (23 KW) per oven ICVD

Electrical Requirements

120 VAC, 1ph, 60 Hz, 9 amps max. (per oven)
Two speed motor - 1/2 h.p., 1725/1140 RPM.

Minimum Clearance

For use only on non-combustible floors with legs or casters; or 2 1/4" (57) overhang is required when curb mounted. 0" clearance from non-combustible sides and rear wall. Provide 6" (152) minimum clearance from combustible side walls and 0" from combustible wall at rear.

Certifications and Listings

■ AGA and CGA design certified, NSF and CE listed.



Options

- Stainless steel stand with bottom shelf and adjustable rack supports
- Stainless steel enclosure back
- Heavy duty 6" (152) swivel casters
- Stacking kit with 6" (152) stainless steel legs
- Cook and Hold computer control

AIA File #:

Imperial Commercial Cooking Equipment

1128 Sherborn Street ■ Corona, CA 92879 ■ 800.343.7790 ■ Ph: 951.281.1830 ■ Fx: 951.281.1879
www.imperialrange.com ■ E-mail: imperialsales@imperialrange.com