

MP 450 Combi



Easy Plug

**D** Pan capacity up to 100 L.

▶ Specially designed for intensive use in commercial/institutional catering

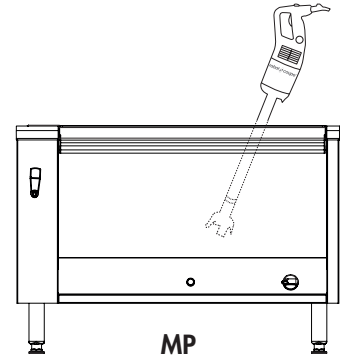

**A SALES DESCRIPTION**

Ideal for blending soups and puréeing fruit and vegetables. Special institutional catering model intended for intensive use. In its Combi version, the whisk function can be used for mashed potato and pancake batter.

**B TECHNICAL DESCRIPTION**

MP 450 Combi Immersion Blenders. 120V/60/1. Power: 720 W /1.1 HP. Variable speed: 3,000 to 10,000 rpm (blender function) and 500 to 1,500 rpm (whisk function). 100% stainless-steel blades, bell and shaft (total length: 18"). « Easy plug » system with detachable power cord.

**C TECHNICAL CHARACTERISTICS**

Effective output	720 W /1.1 HP
Electrical data	120V/60/1 5.5 amps – plug supplied
Variable speed	3,000 to 10,000 rpm (blender function) 500 to 1,500 rpm (whisk function)
Recyclability	95%
Net weight	15 lbs
Reference	MP450COMBI

**E CHARACTERISTICS AND BENEFITS**

**MOTOR UNIT**

- Power 720 W /1.1 HP
- Stainless-steel motor unit with air vents in the top section only to ensure watertightness
- Ridge on motor housing serves as a rest and pivot on the pan rim for greater user comfort
- Variable speed 3,000 - 10,000 rpm (blender function) and 500 - 1,500 rpm (whisk function)
- New patented « Easy plug » system making it easier to replace the power cord during after-sales servicing
- Cord winding system for tidy storage and optimum lifespan
- Indicator light to check if the power cord is properly connected

**SHAFT AND BELL**

- 100% stainless-steel blades, bell and shaft (total length: 18")
- Foot with detachable bell and blades (patented system exclusive to Robot Coupe) for optimum sanitation.
- Watertight bell design for optimum lifespan
- Sturdy all-metal housing for whisk attachment to handle very thick mixtures

**STANDARD ATTACHMENTS**

- Wall-mounted Immersion Blenders holder
- Tool for attaching and detaching the blades

**STANDARDS**

ETL electrical and sanitation Listed/ cETL (Canada)



MP 450 Combi

# MP 450 Combi

MP 450 Combi

G

## DRAWINGS & DIMENSIONS

120V/60/1 – power cord and plug supplied

