

I C E C R E A M F R E E Z E R

DOUBLE SCOOP OF QUALITY



Model SKFS2

- Efficient and durable cold wall design
- Provides optimum dipping temperature
- Stainless steel lid with heavy-duty hinges

SILVER KING[®]
WE'VE GOT REFRIGERATION DOWN COLD.[™]

ICE CREAM FREEZER SPECIFICATIONS

MODEL SKFS2	EXTERIOR	Stainless steel front, back and sides.
	INTERIOR	Stainless steel floor and sidewalls. Covered corners and finished edges for easy cleaning.
	INSULATION	Environmentally friendly foamed-in-place polyurethane insulation for maximum strength and durability.
	LID	Fully insulated stainless steel lid with heavy-duty hinges and handles.
	CASTERS	Supplied with heavy-duty casters, (two with locks), secured to 14 gauge steel base to ensure years of trouble free operation.
	REFRIGERATION	CFC-free, R-134a refrigerant, hermetically sealed, high efficiency, self contained refrigeration system with adjustable temperature control and manual defrost.
	ELECTRICAL	Standard as 115 volt, 60Hz, single phase operation. 8 foot, 3-wire power cord with NEMA 5-15P plug.
	LISTINGS	ETL (U.S. and Canada), NSF International
	WARRANTY	One year materials and workmanship warranty on cabinet. Five year warranty on compressor.

MODEL	OUTSIDE DIMENSIONS			STORAGE CAPACITY	AMPS	COMPRESSOR	SHIPPING WEIGHT
	HEIGHT	WIDTH	DEPTH				
SKFS2	37 3/4"	14 3/4"	23 3/4"	2.78 cu. ft.	1.6	1/10 hp	115 lbs



Specifications subject to change without notice.

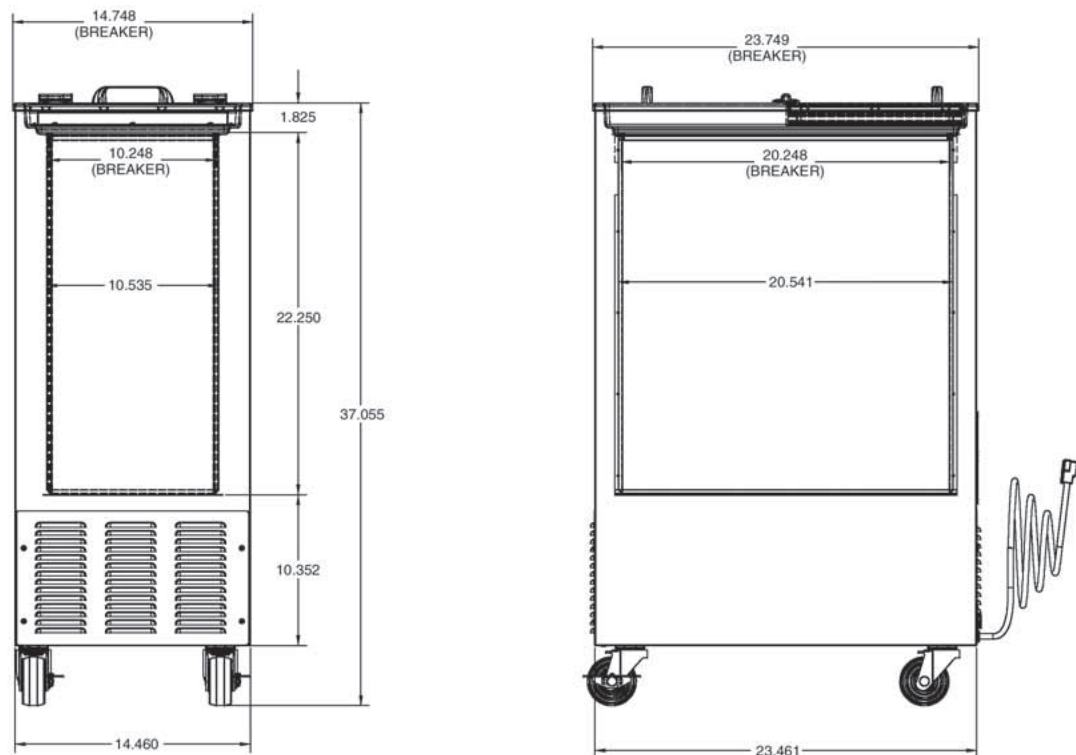

1600 Xenium Lane North
 Minneapolis, MN 55441-3787
 Phone (763) 923-2441
 Fax (763) 553-1209
www.silverking.com

#FNSKFS207
 © Silver King 2007
 Printed in U.S.A.