

REFRIGERATOR MANUFACTURER  
**Turbo air**

*Turbo Air Speed up the Pace of Innovation*

**CAUTION!**  
PLEASE KEEP POWER  
SWITCH ON BEFORE  
OPERATING THIS EQUIPMENT

# Underbar Equipment Club Top Beer Dispensers Installation and Operation Manual

Please read this manual completely before attempting to install or operate this equipment!

TCB-2SD    TCB-2SB  
TCB-3SD    TCB-3SB  
TCB-4SD    TCB-4SB



SD series: Stainless Steel Exterior

SB series: Black Laminated Vinyl Exterior or Black Powder Coating Exterior

[www.turboairinc.com](http://www.turboairinc.com)

## CONTENTS

	PAGE
SPECIFICATION .....	2
SERIAL NUMBER .....	2
INSTALLATION OF THE CASTERS .....	3
Draft Arms Towers Installation Schematic Diagram .....	3
Beer Line & CO <sub>2</sub> Line Installation Schematic Diagram .....	4
Caution "IMPORTANT" .....	5-6
INSTALLATION .....	7
CLEANING .....	8
BASIC OPERATION .....	9
BEFORE REQUESTING SERVICE .....	10
WARRANTY .....	11-12

## SPECIFICATIONS

MODEL	COMPH.P.	V/Hz	REFRIGERANT	AMPS	WEIGHT
TCB-2SD/SB	1/3	110-120V/60Hz	R-134a	7.0A	355 lbs
TCB-3SD/SB	1/3	110-120V/60Hz	R-134a	7.0A	375 lbs
TCB-4SD/SB	1/3	110-120V/60Hz	R-134a	7.5A	445 lbs

## SERIAL NUMBER

The serial number is located on the rating label which is on interior left side wall. Please retain the unit's serial number for service purpose.

## INSTALLATION OF THE CASTERS

According to model, refer to the assembly position of casters.

**TCB-2SD, TBD-2SD, TBB-2SB, TBB-2SG**  
**TCB-3SD, TBD-3SD, TBB-3SB, TBB-3SG**

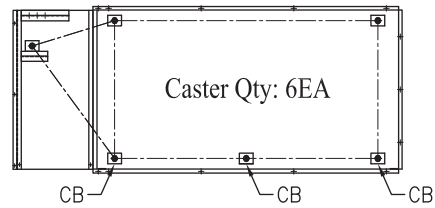

**TCB-4SD, TBD-4SD, TBB-4SB, TBB-4SG**

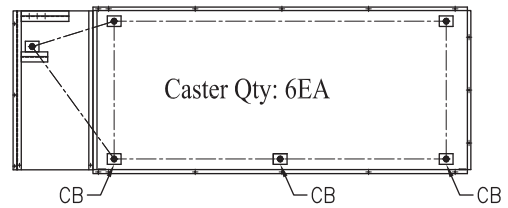

This picture is a plan view of bottom cabinets.  
CB is an abbreviation of the caster with a brake.  
Other casters don't have a brake.

## DRAFT ARMS TOWERS Installation Schematic Diagram

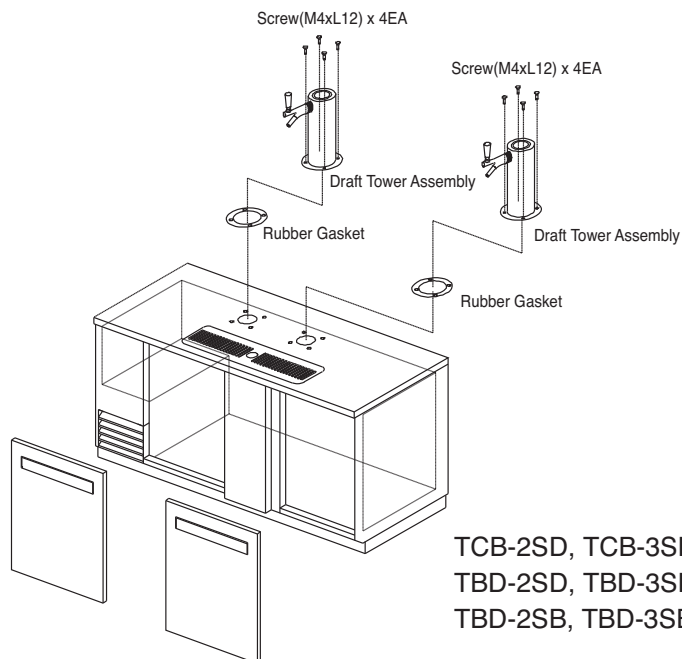

\* Assemble DRAFT TOWER as above drawing.

## BEER LINE & CO<sub>2</sub> LINE Installation Schematic Diagram

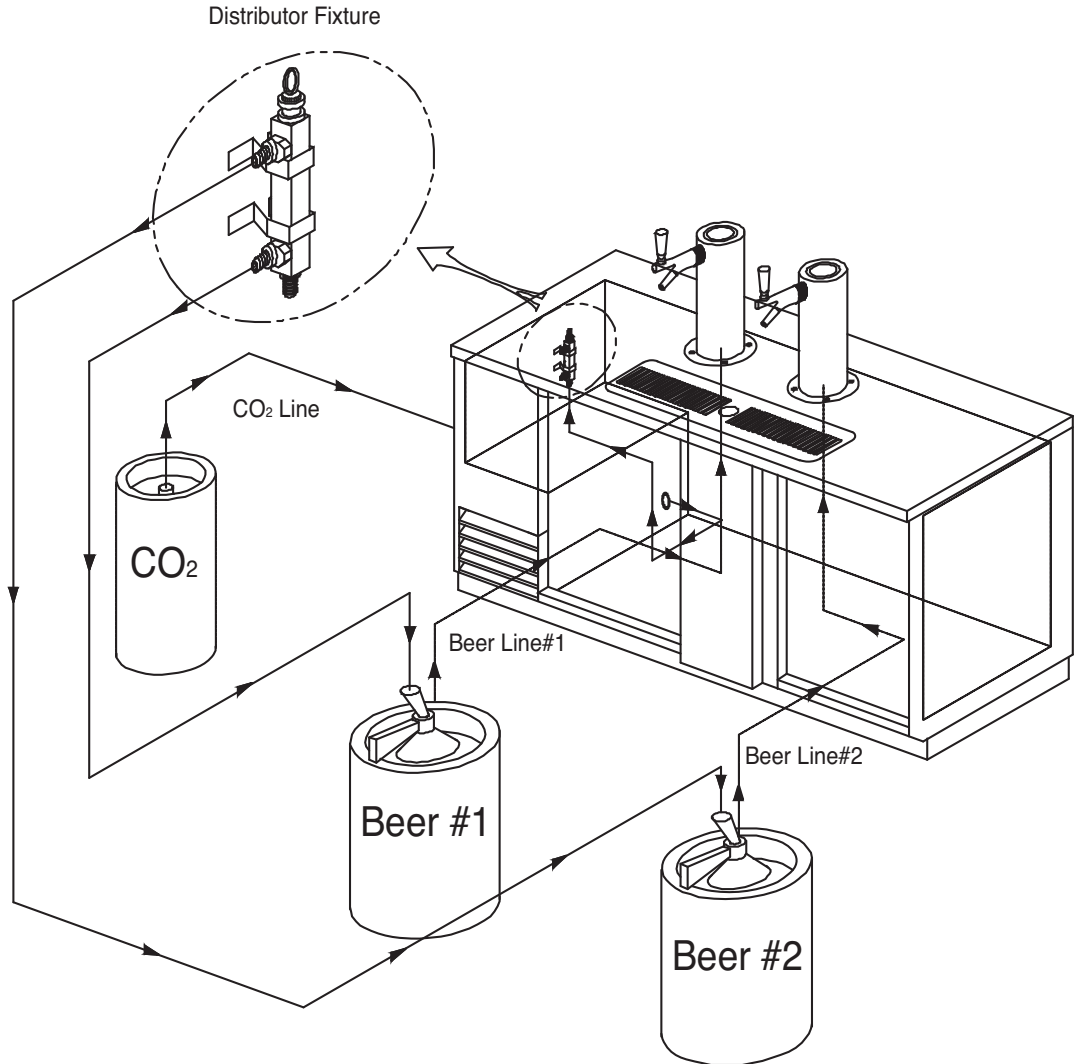

TCB-2SD, TCB-3SD, TCB-4SD  
TBD-2SD, TBD-3SD, TBD-4SD  
TBD-2SB, TBD-3SB, TBD-4SB

\* Assemble BEER LINE & CO<sub>2</sub> LINE as above drawing.

**CAUTION "IMPORTANT"**

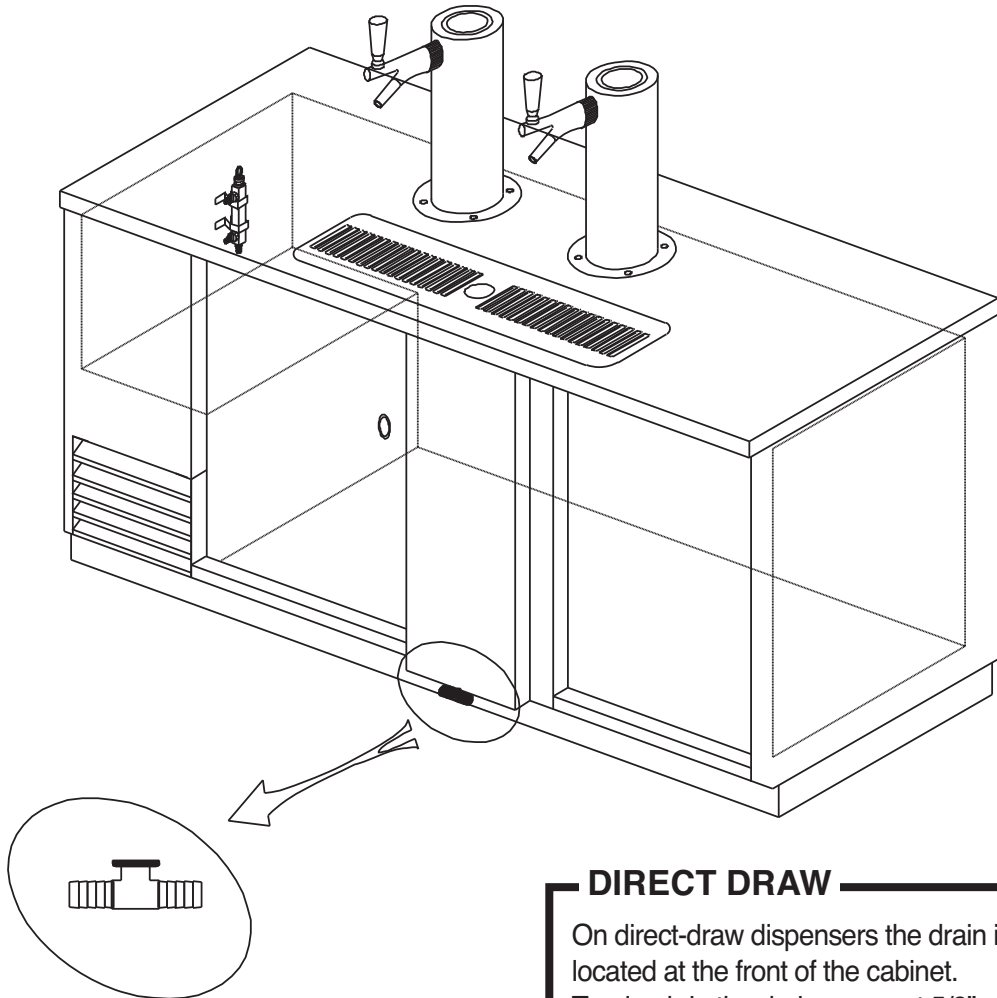

**DIRECT DRAW**

On direct-draw dispensers the drain is located at the front of the cabinet. To plumb in the drain, connect 5/8" P.V.C. pipe to the 5/8" barbed fitting supplies with the unit.

\* Don't pull out or Turn drain line.

## CAUTION "IMPORTANT"

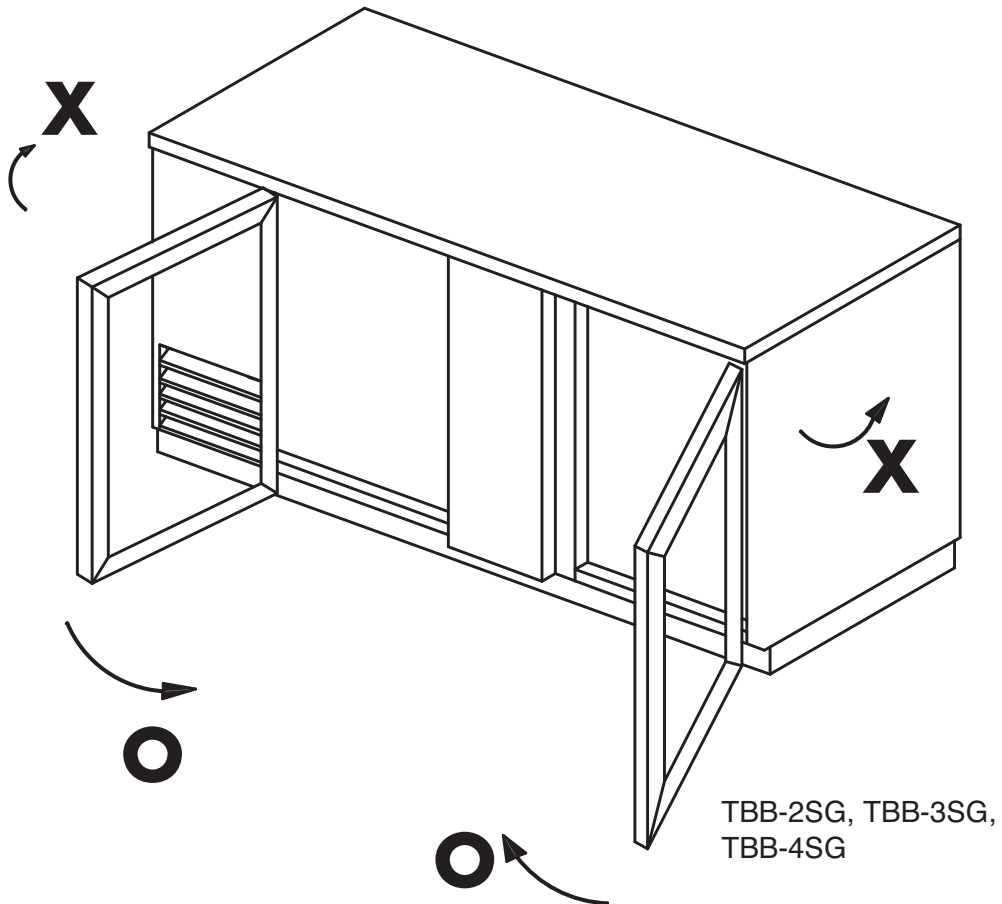

- A. Excessively opening the door will cause the breakdown.
- B. Handle with care as shutting the door.

### 1. POWER CORD

- Be sure the power cord is connected to the proper voltage, and amps should be run before connecting power cord to outlet.
- A protected circuit of the correct voltage and amperage must be run for connection of the line cord.
- Unplug the unit, whenever performing maintenance functions or cleaning the refrigerated cabinet.
- Compressor warranty is void if burnt out due to low voltage.

### 2. RE-STARTING

- If unplugged, wait 5 minutes before re-starting.

# INSTALLATION

## 1. GOOD AIR CIRCULATION

- Do not place any object that will restrict air flow in front or back grills.
- Turbo air highly recommends that there is ample space in rear of unit. 3 inches or more is best.

## 2. PLACE ON STRONG GROUND

- Be sure the location chosen has a floor strong enough to support the total weight of the cabinet and contents.

## 3. DO NOT PLACE NEAR HEAT

- Be sure to avoid hot corners and locations near stoves.
- High ambient temperature will make cooling efficiency lower.

## 4. INDOOR USAGE ONLY

- Be sure to install this unit indoor, so it will not get wet from the rain.

## 5. STABILIZING

- Make sure the unit is installed in a stable condition.

## 6. LEVELING

- Be sure that the unit is level from front to back and side to side.

## 7. Do not plug in with other units on same breaker.

## 8. Do not run on extension cord.

## CLEANING

Before cleaning, unplug the unit.

### 1. CLEANING THE INTERIOR AND EXTERIOR

- The interior and exterior of the unit can be cleaned using warm water with soap.
- Do not use an abrasive cleaner because it will scratch the surface.

### 2. CLEANING THE CONDENSER FINS

- To maintain proper refrigeration performance, the Condenser coil must be free of dust, dirt, and grease.  
This will require periodic cleaning. Condenser fins should be cleaned at least every three months (90 days) or as needed.
- To clean condenser, unplug the unit. Condenser can be cleaned with vacuum, brush, or CO<sub>2</sub> (high pressure air).

### 3. CLEAN THE GASKET

- The door gasket should be cleaned frequently to maintain proper sealing.

### 4. CLEAN THE DRAIN PAN

- Empty the Drain Pan which is located under the unit, periodically.
- When reinstalling Drain Pan, make sure Drain Hose is placed back in pan.

### 5. CHECK AFTER CLEANING

- Plug unit back in.
- Check that the unit is operating properly.



## BASIC OPERATION

### REFRIGERATORS

1. The controller(thermostat) is located at the back right inside of the unit.
2. The factory setting maintains about 38°F(3°C) inside.
3. Set toward “counter clock wise” warmer temperature and “clock wise” for colder temperature.

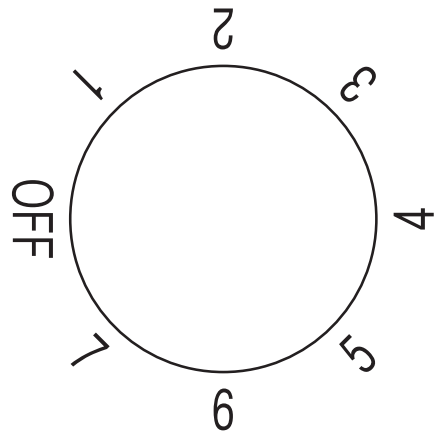
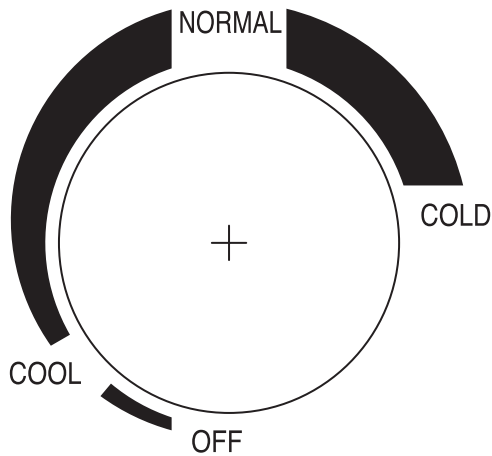

**Temperature Controller  
(Thermostat)**

4. The thermostat controls compressor's cycling by sensing inside temperature.
5. When unit will not be used for a long time, unplug the unit.

## BEFORE REQUESTING SERVICE

SYMPTOMS	CAUSES	SOLUTIONS
<b>Cooler is freezing products</b>	<ul style="list-style-type: none"> <li>• Thermostat set too cold.</li> </ul>	<ul style="list-style-type: none"> <li>• Turn the temperature dial to a warmer setting.</li> </ul>
<b>The unit does not refrigerate at all.</b>	<ul style="list-style-type: none"> <li>• There is a power connection failure problem.</li> </ul>	<ul style="list-style-type: none"> <li>• Check the power cord to make sure the unit is plugged in it correctly.</li> </ul>
<b>The unit does not refrigerate well.</b>	<ul style="list-style-type: none"> <li>• The unit is in sunlight or near a heating device.</li> <li>• Product was put in warm.</li> <li>• The unit lid is opened too frequently or left open too long.</li> <li>• The temp. dial is not on the correct position.</li> <li>• The condenser is clogged.</li> </ul>	<ul style="list-style-type: none"> <li>• Move out of sunlight or away from heater.</li> <li>• Check the condition of stored product.</li> <li>• Check the position of the temp control dial.</li> </ul>
<b>There is a loud noise.</b>	<ul style="list-style-type: none"> <li>• The floor is too weak or the leveling feet are set incorrectly.</li> <li>• The backside of the unit is too close to the wall.</li> </ul>	<ul style="list-style-type: none"> <li>• Check the installation.</li> </ul>
<b>There are dew-drops on the unit exterior.</b>	<ul style="list-style-type: none"> <li>• High-moisture air can produce dewdrops during rainy seasons.</li> </ul>	<ul style="list-style-type: none"> <li>• Wipe with a dry cloth.</li> </ul>
<b>There are dew-drops on the unit interior.</b>	<ul style="list-style-type: none"> <li>• The lid is opened too frequently or left open too long.</li> </ul>	<ul style="list-style-type: none"> <li>• Keep the lid closed to remove dewdrops.</li> </ul>

### The following points are not malfunctions:

- A water-flowing sound can be heard when the compressor stops. This is the sound of REFRIGERANT flowing.
- The compressor does not run during the defrost cycle.

## TWO YEAR WARRANTY

Turbo air warrants to the original purchaser of every new Turbo air refrigerated unit, the cabinet and all parts thereof, to be free from defects in material or workmanship, under normal use and service, for a period of two (2) year from the date of original installation or 27 months after shipment date from Turbo air , whichever occurs first.

Any parts covered by this warranty that are examined and determined by Turbo air to have been defective within two (2) year of original installation or twenty seven (27) months after shipment date from manufacturer, whichever occurs first, shall be repaired or replaced as stated below. Turbo air shall be deemed to have fully complied with its obligation under the foregoing warranties by electing either one of the following procedures, at the sole discretion of Turbo air.

1. Furnishing a replacement part, freight collect, in even exchange for the returned part, freight collect.
2. Receiving the defective part, freight collect; repairing it; and returning it, freight collect.

## ADDITIONAL THREE YEAR COMPRESSOR WARRANTY

In addition to the (2) two year warranty stated above, Turbo air warrants its hermetically and semi-hermetically sealed compressor to be free from defects in both material and workmanship under normal use and service for a period of three (3) additional years from the date of original installation but not to exceed five (5) years and three (3) months after shipment from manufacturer.

Compressors determined by Turbo air have been defective within this extended time period will, at Turbo air's option, be either repaired or replaced with a compressor or compressor parts of similar design and capacity.

The three (3) year extended compressor warranty applies only to hermetically and semi-hermetically sealed parts of the compressor and does not apply to any other parts or components, including, but not limited to, cabinet, paint finish, temperature control, refrigerant, metering device, driers, motor starting equipment, fan assembly any other electrical component, etcetera.

## 134A(404A) COMPRESSOR WARRANTY

The five year compressor warranty detailed above will be voided if the following procedure is not carefully adhered to:

1. This system contains R134A refrigerant and polyol ester lubricant. The Polyol ester lubricant has rapid moisture absorbing qualities. If long exposure to the ambient conditions occur, the lubricant must be removed and replaced with new. Listed below are the approved lubricants for the Tecumseh compressors.

- 1 ICI-Emkarate RL 184
- 2 Emery-2927-A
- 3 Mobile Artic 22A

Failure to comply with recommended lubricant specification will void the compressor warranty.

2. Dryer replacement is very important and must be changed when a system is opened for servicing. dryer must be used with XH-9 desiccant.
3. Micron level vacuums must be achieved to insure low moisture levels in the system. 500 microns or lower must be obtained.

## What is NOT covered by this warranty

Turbo air's sole obligation under this warranty is limited to either repair or replacement of parts, subject to the additional limitations below. This warranty neither assumes nor authorizes any person to assume obligations other than expressly covered by this warranty.

1. **WARRANTY IS NOT TRANSFERABLE.** This warranty is not assignable and applies only in favor of the original purchaser/user to whom delivered. ANY SUCH ASSIGNMENT OR TRANSFER SHALL VOID THE WARRANTIES HEREIN MADE AND SHALL VOID ALL WARRANTIES, EXPRESS OR IMPLIED, INCLUDING ANY WARRANTY OF MERCHANTABILITY OR FITNESS FOR A PARTICULAR PURPOSE.
2. **NO CONSEQUENTIAL DAMAGES.** TURBO AIR IS NOT RESPONSIBLE FOR ECONOMIC LOSS; PROFIT LOSS OR SPECIAL, INDIRECT, OR CONSEQUENTIAL DAMAGES, INCLUDING WITHOUT LIMITATION, LOSSES OR DAMAGES ARISING FROM FOOD OR PRODUCT SPOilage CLAIMS WHETHER OR NOT ON ACCOUNT OF REFRIGERATION FAILURE.
3. **ALTERATION, NEGLIGENCE, ABUSE, MISUSE, ACCIDENT, DAMAGE DURING TRANSIT OR INSTALLATION, FIRE, FLOOD, ACTS OF GOD.** TURBO AIR is not responsible for the repair or replacement of any parts that Turbo Air determines have been subjected after the date of manufacture to alteration, neglect, abuse, misuse, accident, damage during transit or installation, fire, flood, or an Act of God.
4. **NO IMPLIED WARRANTY OF MERCHANTABILITY OR FITNESS FOR A PARTICULAR PURPOSE.** THERE ARE NO OTHER WARRANTIES, EXPRESS, IMPLIED OR STATUTORY, EXCEPT THE TWO(2) YEAR WARRANTY AND THE ADDITIONAL THREE (3) YEAR COMPRESSOR WARRANTY AS DESCRIBED ABOVE. THESE WARRANTIES ARE EXCLUSIVE AND IN LIEU OF ALL OTHER WARRANTIES, INCLUDING IMPLIED WARRANTY AND MERCHANTABILITY OR FITNESS FOR A PARTICULAR PURPOSE. THERE ARE NO WARRANTIES WHICH EXTEND BEYOND THE DESCRIPTION ON THE FACE HEREOF.
5. **TRANSPORTATION COSTS.** Turbo Air will accept parts covered under this warranty freight collect, provided that shipment has received prior approval. Turbo Air is not responsible for any other transportation costs, but will ship freight collect parts either repaired or replaced under these warranties.
6. **WARRANTY CLAIMS.** All claims should include: model number of the cooler, the serial number of the cabinet, proof of purchase, date of installation, and all pertinent information supporting the existence of the alleged defect. Any action or breach of these warranty provisions must be commenced within two (2) year after that cause of action has accrued.

---

**Turbo air** REFRIGERATOR MANUFACTURER

4184 E. Conant St.  
Long Beach, CA 90808  
TEL : 310-900-1000  
FAX : 310-900-1077  
TOLL FREE : 1-800-627-0032  
(U.S.A. & Canada)  
Website : [www.turboairinc.com](http://www.turboairinc.com)

### **Warranty Claims...**

All claims for parts or labor must be made directly through Turbo Air.

All claims should include: model number of the unit, the serial number of the cabinet, proof of purchase, date of installation, and all pertinent information supporting the alleged defect.

In case of compressor replacement under warranty, either compressor or compressor tag must be returned to Turbo Air along with above listed information.

Failure to comply with warranty policies will result in voiding claims.

### **Two Year Parts & Labor Warranty...**

Turbo Air warrants all new refrigerated components, the cabinet and all parts, to be free from defects in materials or workmanship, under normal and proper use and maintenance service as specified by Turbo Air and upon proper installation and start-up in accordance with the instruction packet supplied with each Turbo air unit. Turbo Air's obligation under this warranty is limited to a period of two (2) year from the date of original installation or 27 months after shipment date from Turbo Air, whichever occurs first.

Any part, covered under this warranty, that are by Turbo Air to have been defective within two (2) year of original installation or twenty seven (27) months after shipment date from manufacturer, whichever occurs first, is limited to the repair or replacement, including labor charges, of defective parts or assemblies. The labor warranty shall include standard straight time labor charges only and reasonable travel time, as determined by Turbo Air.

### **Additional Three Year Compressor Warranty...**

In addition to the two (2) year warranty stated above, Turbo Air warrants its hermetically sealed compressor to be free from defects in both material and workmanship under normal and proper use and maintenance service for a period of three (3) additional years from the date of original installation, but not to exceed five (5) years and three(3) months after shipment from the manufacturer.

Compressor determined by Turbo Air to have been defective within this extended period will, at Turbo Air's discretion, be either repaired or replaced with a compressor or compressor parts of similar design and capacity.

The three (3) year extended compressor warranty applies only to hermetically sealed parts of the compressor and does not apply to any other parts or components, including, but not limited to, cabinet, paint finish, temperature control, refrigerant, metering device, driers, motor starting equipment, fan assembly or and other electrical components, etcetera.

### **404A / 134a Compressor Warranty...**

The five-year compressor warranty detailed above will be void if the following procedure is not carefully adhered to:

1. This system contains R404A or R134a refrigerant and polyol ester lubricant. The polyol ester lubricant has rapid moisture absorbing qualities.
2. Drier replacement is very important and must be changed when a system is opened for servicing. A620 copper drier or better is highly recommended.
3. Micron level vacuums must be achieved to insure low moisture levels in the system. 500 microns or lower must be obtained.
4. When compressor is grounded, suction drier and 620 drier or better must be replaced.
5. Compressor must be obtained through Turbo Air, unless otherwise specified in writing, through Turbo Air's warranty department.

### **404A / 134a Compressor Warranty...**

Turbo Air's sole obligation under this warranty is limited to either repair or replacement of parts, subject to the additional limitations below. This warranty neither assumes nor authorizes any person to assume obligations other than those expressly covered by this warranty.

NO CONSEQUENTIAL DAMAGES. TURBO AIR IS NOT RESPONSIBLE FOR ECONOMIC LOSS; PROFIT LOSS; OR SPECIAL, INDIRECT, OR CONSEQUENTIAL DAMAGES, INCLUDING WITHOUT LIMITATION, LOSSES, OR DAMAGES ARISING FROM FOOD OR PRODUCT SPOILAGE REGARDLESS OF WHETHER OR NOT THEY RESULT FROM REFRIGERATION FAILURE.

WARRANTY IS NOT TRANSFERABLE, This warranty is not assignable and applies only in favor of the original purchaser/user to whom delivered. ANY SUCH ASSIGNMENT OR TRANSFER SHALL VOID THE WARRANTIES HEREIN AND SHALL VOID ALL WARRANTIES, EXPRESS OR IMPLIED, INCLUDING ANY WARRANTY OF MERCHANTABILITY OR LABOR COVERAGE FOR COMPONENT FAILURE OR OTHER THE WARRANTY PACKET PROVIDED WITH THE UNIT.

ALTERATION, NEGLIGENCE, ABUSE, MISUSE, ACCIDENT, DAMAGE DURING TRANSIT OR INSTALLATION, FIRE, FLOOD, ACTS OF GOD. Turbo Air is not responsible for the repair or replacement of any parts that Turbo Air determines have been subjected after the date of manufacture to alteration, neglect, abuse, misuse, accident, damage during transit or installation, fire, flood, or act of GOD.

IMPROPER ELECTRICAL CONNECTIONS. TURBO AIR IS NOT RESPONSIBLE FOR THE REPAIR OR REPLACEMENT OF FAILED OR DAMAGED COMPONENTS RESULTING FROM ELECTRICAL POWER FAILURE, THE USE OF EXTENSION CORDS, LOW VOLTAGE, OR VOLTAGE DROPS TO THE UNIT. NO IMPLIED WARRANTY OF MERCHANTABILITY OR FITNESS FOR A PARTICULAR PURPOSE; THERE ARE NO OTHER WARRANTIES, EXPRESSED, IMPLIED OR STATUTORY, EXCEPT THE TWO (2) YEAR PARTS & LABOR WARRANTY AND THE ADDITIONAL THREE (3) YEAR COMPRESSOR WARRANTY AS DESCRIBED ABOVE. THESE WARRANTIES ARE EXCLUSIVE AND IN LIEU OF ALL OTHER WARRANTIES, INCLUDING IMPLIED WARRANTY AND MERCHANTABILITY OR FITNESS FOR A PARTICULAR PURPOSE. THERE ARE NO WARRANTIES, WHICH EXTEND BEYOND THE DESCRIPTION ON THE FACE HEREOF.

Outside U.S. and Canada; This warranty does not apply to, and Turbo Air is not responsible for, any warranty claims made on products sold or used outside the continent of the United States and Canada.