

**CAUTION!**  
PLEASE KEEP POWER  
SWITCH ON BEFORE  
OPERATING THIS EQUIPMENT

# Display Case Bakery Case Installation and Operation Manual

Please read this manual completely before attempting to install or operate this equipment!

## **Refrigerated Case**

TCGB-36-2

TCGB-48-2

TCGB-60-2

TCGB-72-2

## **Combination Case**

TCGB-60-CO

TCGB-72-CO

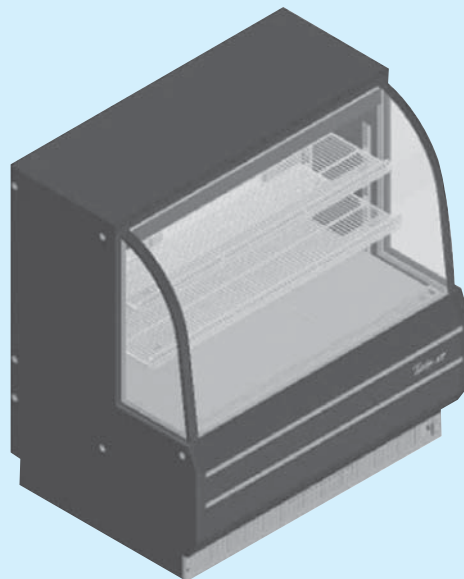

# CONTENTS

INTRODUCTION .....	3 - 4
SPECIFICATION .....	5
INSTALLATION INSTRUCTIONS .....	6 - 7
Inspection for damage	
Location of Display	
Leveling of Display	
OPERATING INSTRUCTIONS .....	7 - 8
Controls	
Power Switch	
Light Switch	
Temperature Control	
Thermometer	
How to place product	
MAINTENANCE & CLEANING .....	8 - 9
Condenser coil	
TROUBLE SHOOTING .....	9 - 10
Display not working	
Display case warm	
Lights not working	
WIRING DIAGRAM .....	11
WARRANTY STATEMENT .....	12 - 14

## INTRODUCTION

This owner's manual has important information. Please read the entire manual before installing your new Turbo Air Open Display Merchandiser. After reading manual if you have any questions, please feel free to call:

**CUSTOMER SERVICE DEPARTMENT  
TURBO AIR  
1250 VICTORIA ST.  
CARSON, CA 90746  
1-800-381-7770**

Please write down model and serial number for making any reference to this unit.

**MODEL NUMBER** \_\_\_\_\_

**SERIAL NUMBER** \_\_\_\_\_

## WARNING

Failure to read this manual completely can result in personal injury or damage to the unit.

Keep manual in a safe place to refer to in the future.

Display should be on dedicated outlet for proper operation.

***Thank you for purchasing Turbo Air!***

## SPECIFICATION

Model	TCGB-36-2*	TCGB-48-2*	TCGB-60-2*	TCGB-72-2*
Dimension (L×D×H)	36.5×34.2× 50.5	48.5×34.2× 50.5	60.5×34.2× 50.5	72.5×34.2× 50.5
Electricity	120V/1Ph/60Hz			
Power Input	6.5A		11.0A	
Compressor	HK6A1C2U		CAJ4476Y	
Refrigerant	R-134a			
Lighting	9.6W×3	13.2W×3	16.8W×3	20.4W×3
Defrosting	Timed off defrost			
Weight of Case	416.67	524.70	584.22	698.86

Model	TCGB-60-2-CO*	TCGB-72-2-CO*
Dimension (L×D×H)	60.5×34.2×50.5	72.5×34.2×50.5
Electricity	120V/1Ph/60Hz	
Power Input	6.5A	
Compressor	HK6A1C2U	
Refrigerant	R-134a	
Lighting	7.2W×6	9.6W×6
Defrosting	Timed off defrost	
Weight of Case	629.22	743.86

## INSTALLATION INSTRUCTIONS

### **INSPECTION FOR DAMAGE**

---

The customer is responsible for checking for damage. First inspect the crate as soon as it arrives. If crate is damaged make sure you note that on bill of lading prior to signing. If after uncrating there is concealed damage and the crate was in good condition you must call Customer Service at Turbo Air. Concealed damage must be reported within 24 hours of receiving the unit. It will be requested to fax the Bill of lading to the claims department. Pictures of unit and crating may be requested.

### **LOCATION OF OPEN DISPLAY MERCHANDISER**

---

The Display is designed to be in an ambient 75 degrees Fahrenheit (dry bulb) or colder environment with 55 percent relative humidity or less. If unit is installed in a warm ambient environment, the Display will not cool effectively. Move the display to the final location before removing shipping skid. Allow 3 inches from back of Display to wall. The condenser is in front of the Display. Do not block the inlet.

There are four bolts at the bottom of the display that secure it to the shipping skid, remove all four.

### **LEVELING OF DISPLAY**

---

Please install on a level surface.

Installation on a surface that is not level could lead to damage to the glass.

## INSTALLATION INSTRUCTIONS

### MERCHANDISER

---

Four leveling legs are provided for leveling the Display. If you do not wish to use levelers they can be turned inwards.

The bottom frame of the unit will be on the floor. Use a leveler to make sure unit is leveled on all four corners.

If unit is not leveled water will not drain properly. Leveling legs can be adjusted accordingly

## OPERATING INSTRUCTIONS

After installing unit and all electrical parts to the Display, the Display is ready to start up.

### CONTROLS

---

**POWER SWITCH:** It is located in front of front panel down on red.

**LIGHT SWITCH:** It is located in front of front panel down on green.

**TEMPERATURE CONTROL:** The temperature control is located near the back left hand side underneath the bottom shelf.

1. The original setting for the control is Normal.
2. The working temperature is from 37°F to 40°F.
3. To lower the temperature, turn the knob slightly to “COLD”. To raise the temperature, turn the knob to “WARM”.
4. In case of icing due to the hike of ambient temperature or humidity, turn the knob slightly to “WARM”

## OPERATING INSTRUCTIONS

### THERMOMETER:

Thermometer showing temperature is located on the Front right hand side underneath the shelf.

### NOTE:

Before placing products for Display wait for the unit to reach the desired temperature. Do not place hot products in the unit.

### HOW TO PLACE PRODUCT:

Do not overload products on the shelves. Do not place products against the back wall, as air flow may be blocked and interfere with proper unit cooling.

## MAINTENANCE & CLEANING

!!! The unit should always be turned off at the power switch and lights, before cleaning the display.

Unit should be turned off. Remove product and allow display to reach room temperature

!!! Do not get electrical components wet.

### **DISPLAY CASE SHOULD BE CLEANED THOROUGHLY BEFORE FIRST USE.**

---

- a. Do not clean with harsh detergents. Use a mild soap
- b. Remove all products.
- c. Remove shelves and bottom trays.



## MAINTENANCE & CLEANING

- d. Clean interior with warm water and mild detergent.
- e. Wipe with a damp cloth. Do not leave soap residue.

### CONDENSER COIL

---

Condenser coil is located at bottom behind panel.



1. Disconnect the electrical power to the unit
2. Remove the front cover and base cover with screwdriver
3. Brush the dirt, lint, etc from the finned condenser coil.
4. When finished, be sure to replace the front cover and base cover
5. Reconnect the electrical power to the unit.
6. Condenser should be cleaned every 3 months or as needed.

## TROUBLE SHOOTING

For any problems with the Display please refer to following check list. If you still have a problem or need to ask a question please call Customer service at 1-800-381-7770.

## TROUBLE SHOOTING

### **DISPLAY NOT WORKING**

---

- a. Check to see if breaker is not tripped.
- b. Check power going to unit.
- c. Check power switch is on.

### **DISPLAY CASE WAR**

---

- a. Check condenser to see if clean
- b. Check that air flow inside of unit is not blocked with product.

### **LIGHTS NOT WORKING**

---

- a. Check that light switch is on.
- b. Check that light is in lamp holder correctly.

# WIRING DIAGRAM

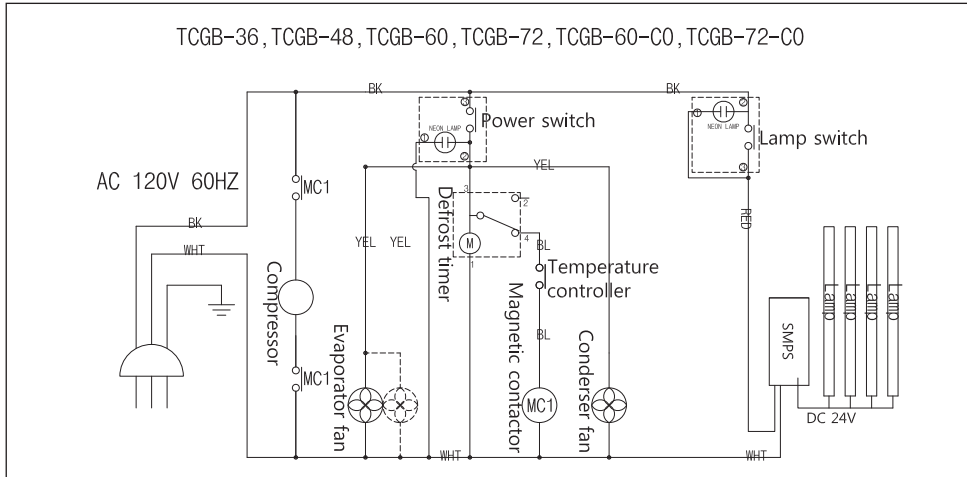

## TWO YEAR WARRANTY

Turbo air warrants to the original purchaser of every new Turbo air refrigerated unit, the cabinet and all parts thereof, to be free from defects in material or workmanship, under normal use and service, for a period of two (2) year from the date of original installation or 27 months after shipment date from Turbo air , whichever occurs first.

Any parts covered by this warranty that are examined and determined by Turbo air to have been defective within two (2) year of original installation or twenty seven (27) months after shipment date from manufacturer, whichever occurs first, shall be repaired or replaced as stated below. Turbo air shall be deemed to have fully complied with its obligation under the foregoing warranties by electing either one of the following procedures, at the sole discretion of Turbo air.

1. Furnishing a replacement part, freight collect, in even exchange for the returned part, freight collect.
2. Receiving the defective part, freight collect; repairing it; and returning it, freight collect.

## ADDITIONAL THREE YEAR COMPRESSOR WARRANTY

In addition to the (2) two year warranty stated above, Turbo air warrants its hermetically and semi-hermetically sealed compressor to be free from defects in both material and workmanship under normal use and service for a period of three (3) additional years from the date of original installation but not to exceed five (5) years and three (3) months after shipment from manufacturer.

Compressors determined by Turbo air have been defective within this extended time period will, at Turbo air's option, be either repaired or replaced with a compressor or compressor parts of similar design and capacity.

The three (3) year extended compressor warranty applies only to hermetically and semi-hermetically sealed parts of the compressor and does not apply to any other parts or components, including, but not limited to, cabinet, paint finish, temperature control, refrigerant, metering device, driers, motor starting equipment, fan assembly any other electrical component, etcetera.

## 134A(404A) COMPRESSOR WARRANTY

The five year compressor warranty detailed above will be voided if the following procedure is not carefully adhered to:

1. This system contains R134A refrigerant and polyol ester lubricant. The Polyol ester lubricant has rapid moisture absorbing qualities. If long exposure to the ambient conditions occur, the lubricant must be removed and replaced with new. Listed below are the approved lubricants for the Tecumseh compressors.

- 1 ICI-Emkarate RL 184
- 2 Emery-2927-A
- 3 Mobile Artic 22A

Failure to comply with recommended lubricant specification will void the compressor warranty.

2. Dryer replacement is very important and must be changed when a system is opened for servicing. dryer must be used with XH-9 desiccant.
3. Micron level vacuums must be achieved to insure low moisture levels in the system. 500 microns or lower must obtained.

## What is NOT covered by this warranty

Turbo air's sole obligation under this warranty is limited to either repair or replacement of parts, subject to the additional limitations below. This warranty neither assumes nor authorizes any person to assume obligations other than expressly covered by this warranty.

1. **WARRANTY IS NOT TRANSFERABLE.** This warranty is not assignable and applies only in favor of the original purchaser/user to whom delivered. ANY SUCH ASSIGNMENT OR TRANSFER SHALL VOID THE WARRANTIES HEREIN MADE AND SHALL VOID ALL WARRANTIES, EXPRESS OR IMPLIED, INCLUDING ANY WARRANTY OF MERCHANTABILITY OR FITNESS FOR A PARTICULAR PURPOSE.
2. **NO CONSEQUENTIAL DAMAGES.** TURBO AIR IS NOT RESPONSIBLE FOR ECONOMIC LOSS; PROFIT LOSS OR SPECIAL, INDIRECT, OR CONSEQUENTIAL DAMAGES, INCLUDING WITHOUT LIMITATION, LOSSES OR DAMAGES ARISING FROM FOOD OR PRODUCT SPOilage CLAIMS WHETHER OR NOT ON ACCOUNT OF REFRIGERATION FAILURE.
3. **ALTERATION, NEGLIGENCE, ABUSE, MISUSE, ACCIDENT, DAMAGE DURING TRANSIT OR INSTALLATION, FIRE, FLOOD, ACTS OF GOD.** TURBO AIR is not responsible for the repair or replacement of any parts that Turbo Air determines have been subjected after the date of manufacture to alteration, neglect, abuse, misuse, accident, damage during transit or installation, fire, flood, or an Act of God.
4. **NO IMPLIED WARRANTY OF MERCHANTABILITY OR FITNESS FOR A PARTICULAR PURPOSE.** THERE ARE NO OTHER WARRANTIES, EXPRESS, IMPLIED OR STATUTORY, EXCEPT THE TWO(2) YEAR WARRANTY AND THE ADDITIONAL THREE (3) YEAR COMPRESSOR WARRANTY AS DESCRIBED ABOVE. THESE WARRANTIES ARE EXCLUSIVE AND IN LIEU OF ALL OTHER WARRANTIES, INCLUDING IMPLIED WARRANTY AND MERCHANTABILITY OR FITNESS FOR A PARTICULAR PURPOSE. THERE ARE NO WARRANTIES WHICH EXTEND BEYOND THE DESCRIPTION ON THE FACE HEREOF.
5. **TRANSPORTATION COSTS.** Turbo Air will accept parts covered under this warranty freight collect, provided that shipment has received prior approval. Turbo Air is not responsible for any other transportation costs, but will ship freight collect parts either repaired or replaced under these warranties.
6. **WARRANTY CLAIMS.** All claims should include: model number of the cooler, the serial number of the cabinet, proof of purchase, date of installation, and all pertinent information supporting the existence of the alleged defect. Any action or breach of these warranty provisions must be commenced within two (2) year after that cause of action has accrued.

---

**Turbo air** REFRIGERATOR MANUFACTURER

4184 E. Conant St.  
Long Beach, CA 90808  
TEL : 310-900-1000  
FAX : 310-900-1077  
TOLL FREE : 1-800-627-0032  
(U.S.A. & Canada)  
Website : [www.turboairinc.com](http://www.turboairinc.com)

### **Warranty Claims...**

All claims for parts or labor must be made directly through Turbo Air.

All claims should include: model number of the unit, the serial number of the cabinet, proof of purchase, date of installation, and all pertinent information supporting the alleged defect.

In case of compressor replacement under warranty, either compressor or compressor tag must be returned to Turbo Air along with above listed information.

Failure to comply with warranty policies will result in voiding claims.

### **Two Year Parts & Labor Warranty...**

Turbo Air warrants all new refrigerated components, the cabinet and all parts, to be free from defects in materials or workmanship, under normal and proper use and maintenance service as specified by Turbo Air and upon proper installation and start-up in accordance with the instruction packet supplied with each Turbo air unit. Turbo Air's obligation under this warranty is limited to a period of two (2) year from the date of original installation or 27 months after shipment date from Turbo Air, whichever occurs first.

Any part, covered under this warranty, that are by Turbo Air to have been defective within two (2) year of original installation or twenty seven (27) months after shipment date from manufacturer, whichever occurs first, is limited to the repair or replacement, including labor charges, of defective parts or assemblies. The labor warranty shall include standard straight time labor charges only and reasonable travel time, as determined by Turbo Air.

### **Additional Three Year Compressor Warranty...**

In addition to the two (2) year warranty stated above, Turbo Air warrants its hermetically sealed compressor to be free from defects in both material and workmanship under normal and proper use and maintenance service for a period of three (3) additional years from the date of original installation, but not to exceed five (5) years and three(3) months after shipment from the manufacturer.

Compressor determined by Turbo Air to have been defective within this extended period will, at Turbo Air's discretion, be either repaired or replaced with a compressor or compressor parts of similar design and capacity.

The three (3) year extended compressor warranty applies only to hermetically sealed parts of the compressor and does not apply to any other parts or components, including, but not limited to, cabinet, paint finish, temperature control, refrigerant, metering device, driers, motor starting equipment, fan assembly or and other electrical components, etcetera.

### **404A / 134a Compressor Warranty...**

The five-year compressor warranty detailed above will be void if the following procedure is not carefully adhered to:

1. This system contains R404A or R134a refrigerant and polyol ester lubricant. The polyol ester lubricant has rapid moisture absorbing qualities.
2. Drier replacement is very important and must be changed when a system is opened for servicing. A620 copper drier or better is highly recommended.
3. Micron level vacuums must be achieved to insure low moisture levels in the system. 500 microns or lower must be obtained.
4. When compressor is grounded, suction drier and 620 drier or better must be replaced.
5. Compressor must be obtained through Turbo Air, unless otherwise specified in writing, through Turbo Air's warranty department.

### **404A / 134a Compressor Warranty...**

Turbo Air's sole obligation under this warranty is limited to either repair or replacement of parts, subject to the additional limitations below. This warranty neither assumes nor authorizes any person to assume obligations other than those expressly covered by this warranty.

NO CONSEQUENTIAL DAMAGES. TURBO AIR IS NOT RESPONSIBLE FOR ECONOMIC LOSS; PROFIT LOSS; OR SPECIAL, INDIRECT, OR CONSEQUENTIAL DAMAGES, INCLUDING WITHOUT LIMITATION, LOSSES, OR DAMAGES ARISING FROM FOOD OR PRODUCT SPOILAGE REGARDLESS OF WHETHER OR NOT THEY RESULT FROM REFRIGERATION FAILURE.

WARRANTY IS NOT TRANSFERABLE, This warranty is not assignable and applies only in favor of the original purchaser/user to whom delivered. ANY SUCH ASSIGNMENT OR TRANSFER SHALL VOID THE WARRANTIES HEREIN AND SHALL VOID ALL WARRANTIES, EXPRESS OR IMPLIED, INCLUDING ANY WARRANTY OF MERCHANTABILITY OR LABOR COVERAGE FOR COMPONENT FAILURE OR OTHER THE WARRANTY PACKET PROVIDED WITH THE UNIT.

ALTERATION, NEGLIGENCE, ABUSE, MISUSE, ACCIDENT, DAMAGE DURING TRANSIT OR INSTALLATION, FIRE, FLOOD, ACTS OF GOD. Turbo Air is not responsible for the repair or replacement of any parts that Turbo Air determines have been subjected after the date of manufacture to alteration, neglect, abuse, misuse, accident, damage during transit or installation, fire, flood, or act of GOD.

IMPROPER ELECTRICAL CONNECTIONS. TURBO AIR IS NOT RESPONSIBLE FOR THE REPAIR OR REPLACEMENT OF FAILED OR DAMAGED COMPONENTS RESULTING FROM ELECTRICAL POWER FAILURE, THE USE OF EXTENSION CORDS, LOW VOLTAGE, OR VOLTAGE DROPS TO THE UNIT. NO IMPLIED WARRANTY OF MERCHANTABILITY OR FITNESS FOR A PARTICULAR PURPOSE; THERE ARE NO OTHER WARRANTIES, EXPRESSED, IMPLIED OR STATUTORY, EXCEPT THE TWO (2) YEAR PARTS & LABOR WARRANTY AND THE ADDITIONAL THREE (3) YEAR COMPRESSOR WARRANTY AS DESCRIBED ABOVE. THESE WARRANTIES ARE EXCLUSIVE AND IN LIEU OF ALL OTHER WARRANTIES, INCLUDING IMPLIED WARRANTY AND MERCHANTABILITY OR FITNESS FOR A PARTICULAR PURPOSE. THERE ARE NO WARRANTIES, WHICH EXTEND BEYOND THE DESCRIPTION ON THE FACE HEREOF.

Outside U.S. and Canada; This warranty does not apply to, and Turbo Air is not responsible for, any warranty claims made on products sold or used outside the continent of the United States and Canada.