

REFRIGERATOR MANUFACTURER
Turbo air
 more durable, efficient, beautiful

4184 E. Conant St.
 Long Beach, CA 90808
 Tel. 310-900-1000
 Fax. 310-900-1077
www.turboairinc.com

Project :	
Model # :	
Item # :	Qty :
Available W/H :	
Approval :	

Glass Door Refrigerator

*Reach-In Bottom Mount
 Super Deluxe Series*

Model : MSR-49G-2

≡ FEATURES & BENEFITS ≡

- **Digital temperature control system**
 Provides precise and constant temperature. This level of precision allows food products to remain fresh over an extended period of time.
- **High-tech monitor**
 The unit will beep if the door has been opened for more than 30 seconds. The monitor digitally displays the present temperature and current status of the refrigerator. You can easily change the temperature by adjusting the thermostat.
- **Stainless steel interior & exterior with AL sides**
 The Turbo Air Super Deluxe glass door model is constructed with stainless steel top & bottom grilles and clear aluminum coated side panels. The door is glass with AL frame. The interior is stainless steel that guarantees the utmost in cleanliness and long products life. The Super Deluxe can add a touch of style to the most refined setting.
- **LED interior lighting system**
 Brighter and longer lasting LED lights provide attractive, enhanced illumination compared to fluorescents. It saves energy by producing less heat, while maximizing the visibility in the display area.
- **Efficient refrigeration system**
 Turbo Air's glass door refrigerators are designed with oversized and balanced (CFC Free R-134A) refrigeration systems. These include efficient evaporators and condensers for faster cooling and greater efficiency.
- **Automatic evaporator fan motor delays**
 When the door is opened the evaporator fan will stop, preventing the circulation of hot and moist air from escaping into the refrigerator. This increases energy efficiency and lengthens the life of the compressor.
- **High-density polyurethane insulation**
 The entire cabinet structure is foamed-in-place using high density, CFC free polyurethane insulation.
- **Adjustable, heavy duty, PE(polyethylene) coated wire shelves**
- **Ergonomically designed doors**
 Customers' fatigue fades away with easy grip handles and doors that open effortlessly. Self-closing features make this the ultimate choice in customer convenience.
- **Double pane glass doors with Low-E glass**
 Energy saving double pane glass doors are equipped with Low-emissivity glass, which reduce outer heat gain and decrease energy consumption. It enhances energy efficiency and minimizes condensation. Lightweight door construction also reduce door maintenance and bushing wear, which in turn facilitates smoother door openings.



Refrigerator holds 33°F ~ 38°F for the best in food preservation

ENERGY STAR®
 Qualified



Model	Swing Door	CU./FT.	#of Shelves	HP	AMPS	Crated Weight (lbs.)	L x D x H [†] (inches)
MSR-49G-2	2	49	6	1/3	7	480	54 3/8 x 30 3/4 x 78 1/4

Glass Door Refrigerator

Reach-In Bottom Mount
Super Deluxe Series

Model : MSR-49G-2

ELECTRICAL DATA	
Voltage	115/60/1
Plug Type	Ⓜ NEMA-5-15P
Full Load Amperes	7
Compressor HP	1/3
Feed Wires with Ground	3
Cord Length ft.	7
Refrigerant	R-134A
DIMENSIONAL DATA	
# of Doors	2
# of Racks Accepted	2
Net Capacity cu. ft.	49
Ext. Length Overall in.	54 ³ / ₈ (1381mm)
Ext. Depth Overall in.*	30 ³ / ₄ (781mm)
Ext. Height Overall in.†	78 ¹ / ₄ (1987mm)
Int. Length Overall in.	50 ¹ / ₂ (1282mm)
Int. Depth Overall in.	26 ¹ / ₄ (666mm)
Int. Height Overall in.	60 ³ / ₈ (1534mm)
Gross Weight lbs.	480
# of Shelves	6
Shelf Size (LxD) in.	24 ³ / ₈ x 23 ¹ / ₄

Design and specifications subject to change without notice.

Actual shipping weight may differ due to extra packing materials for product protection.

* Depth does not include 1-1/2" for glass door handles.

† Height does not include 5" caster height or 6" optional legs.

■ WARRANTY : 3 Year Parts and Labor Warranty Additional 2 Year Warranty on Compressor

- Door locks standard
- Self-contained system
- Standard 4" swivel casters with locks on the front set
- Easy replaceable one piece magnetic door gaskets
- Solid and sturdy grille design
- Legs available for all models (optional)
- Full and half pan racks available (optional)

■ OPTIONAL ACCESSORIES :

- 5" Diameter swivel casters
- 6" Standard legs
- Additional stainless steel shelves
- Additional PE coated wire shelves
- Half door bun tray racks. Each holds up to seven 18"Lx26"D sheet pans (sold separately)
- Full door bun tray racks. Each holds up to fifteen 18"Lx26"D sheet pans (sold separately)

PLAN VIEW

(unit : inch)

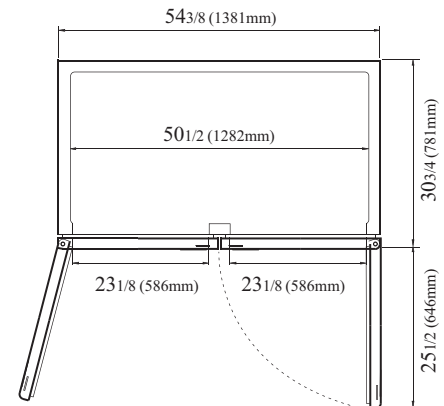

PLAN VIEW

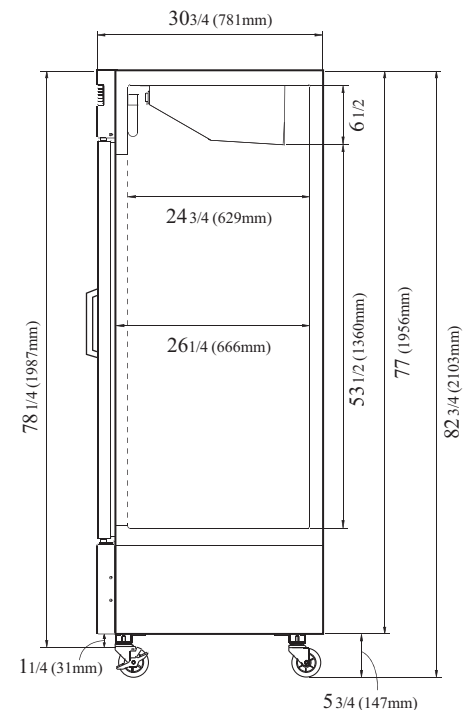

SIDE VIEW

Ver.201501



- Turbo Air : 800-627-0032
- GK : 800-500-3519
- Warranty : 800-381-7770
- AC : 888-900-1002

