

**REFRIGERATOR MANUFACTURER**  
**Turbo air**  
 more durable, efficient, beautiful

4184 E. Conant St.  
 Long Beach, CA 90808  
 Tel. 310-900-1000  
 Fax. 310-900-1077  
[www.turboairinc.com](http://www.turboairinc.com)

Project :	
Model # :	
Item # :	Qty :
Available W/H :	
Approval :	

## Solid Door Refrigerator

Reach-In Top Mount  
 Premiere Spec Series

**Model : PRO-50R**

### ≡ FEATURES & BENEFITS ≡

- **Digital temperature control system**  
 Provides precise and constant temperature. This level of precision allows food products to remain fresh over an extended period of time.
- **High-tech monitor**  
 The unit will beep if the door has been opened for more than 30 seconds. The monitor digitally displays the present temperature and current status of the refrigerator. You can easily change the temperature by adjusting the thermostat.
- **All stainless steel cabinet construction**  
 The Turbo Air Premiere Spec model boasts all stainless steel interior and exterior (galvanized steel top, bottom and back). It guarantees the utmost in cleanliness and long product life. Unlike other companies' products, the sharp corners and edges have been rounded to reduce the risk of injury. The Premiere Spec model can add a touch of style to the most refined setting.
- **Sturdy, clean stainless steel shelving**  
 Shelves are the most important part of cleanliness as they come in direct contact with food. After a while, PVC coated wire shelves may peel, rust and lead to unsanitary conditions. Only the Turbo Air Premiere Spec series uniquely provides stainless steel shelving.
- **Hot gas condensate system**  
 Through Turbo Air's creative innovation, the condensate system surfaces have been specially treated to resist corrosion. This not only increases efficiency without the risk of refrigerant leakage from corrosion, but thoroughly prevents the overflow of condensate water.
- **Cold air distribution system**  
 Provides uniformly maintained temperature within the food zone.
- **LED interior lighting system**  
 Brighter and longer lasting LED lights provide attractive, enhanced illumination compared to fluorescents. It saves energy by producing less heat, while maximizing the visibility.
- **Turbo Cooling feature for faster chilling**  
 The Turbo Cooling function, located on the control panel, allows the compressor to run continuously for up to two hours. When this function is activated, the temperature inside the cabinet quickly decreases and cools drinks, food, and other products much faster. An ideal time to use the Turbo Cooling function is when the unit is stocked with new products.
- **Door pressure release device**  
 Pressure relief doors are designed to eliminate vacuum pressure and allows easy, instant door opening.
- **Efficient refrigeration system**  
 Premiere Spec's solid door refrigerators are designed with oversized and balanced (CFC Free R-134A) refrigeration systems. These include efficient evaporators and condensers for faster cooling and greater efficiency.
- **Automatic evaporator fan motor delays**  
 When the door is opened the evaporator fan will stop, preventing the circulation of hot and moist air from escaping into the refrigerator. This increases energy efficiency and lengthens the life of the compressor.

**3 YEAR PARTS & LABOR WARRANTY**



Refrigerator holds 33°F ~ 38°F for the best in food preservation



Model	Swing Door	CU./FT.	#of Shelves	HP	AMPS	Crated Weight (lbs.)	L x D* x H † (inches)
PRO-50R	2	49	6	1/2	9.1	538	51 3/4 x 33 7/8 x 78

# Solid Door Refrigerator

Reach-In Top Mount  
Premiere Spec Series

## Model : PRO-50R

ELECTRICAL DATA	
Voltage	115/60/1
Plug Type	 NEMA-5-15P
Full Load Amperes	9.1
Compressor HP	1/2
Feed Wires with Ground	3
Cord Length ft.	9
Refrigerant	R-134A
DIMENSIONAL DATA	
# of Doors	2
# of Racks Accepted	2
Net Capacity cu. ft.	49
Ext. Length Overall in.	51 3/4 (1314mm)
Ext. Depth Overall in.*	33 7/8 (860mm)
Ext. Height Overall in.†	78 (1981mm)
Int. Length Overall in.	47 3/4 (1214mm)
Int. Depth Overall in.	29 1/2 (750mm)
Int. Height Overall in.	58 3/4 (1493mm)
Net Weight lbs.	485
Gross Weight lbs.	538
# of Shelves	6
Shelf Size (LxD) in.	23 x 25 1/4

Design and specifications subject to change without notice.

Actual shipping weight may differ due to extra packing materials for product protection.

\* Depth does not include 1-1/8" for door handles. † Height does not include 4-7/8" caster height.

### ■ WARRANTY : 3 Year Parts and Labor Warranty Additional 2 Year Warranty on Compressor

- Door locks standard
- Self-contained system
- Standard 4" swivel casters with locks on the front set
- Easy replaceable one piece magnetic door gaskets
- Solid and sturdy grille design
- High-density polyurethane insulation
- Legs available for all models (optional)
- Full and half pan racks available (optional)

### ■ OPTIONAL ACCESSORIES :

- 5" Diameter swivel casters
- 6" Standard legs
- Additional stainless steel shelves
- Additional PE coated wire shelves
- Half door bun tray racks. Each holds up to seven 18"Lx26"D sheet pans (sold separately)
- Full door bun tray racks. Each holds up to fifteen 18"Lx26"D sheet pans (sold separately)

## PLAN VIEW

(unit : inch)

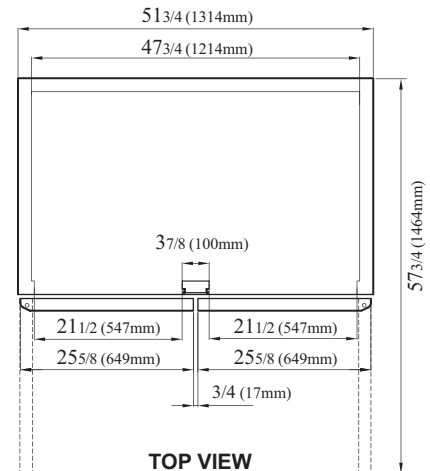

TOP VIEW

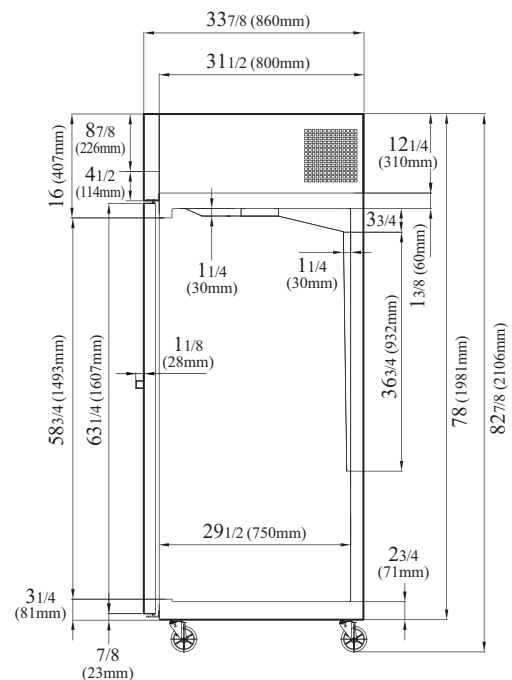

SIDE VIEW

Ver.201501



- Turbo Air : 800-627-0032
- GK : 800-500-3519
- Warranty : 800-381-7770
- AC : 888-900-1002

REFRIGERATOR MANUFACTURER  
**Turbo air**

**GERMAN KNIFE**

**RADIANCE**

**GREEN WORLD**

AIR CONDITIONER MANUFACTURER  
**Turbo air**