

Glass Door Merchandisers

Swing Door Models



TGM-5R



TGM-11RV



TGM-14RV



TGM-22RV

■ **SELF-CLOSING DOORS**

Every Turbo Air display refrigerator features our exclusive magic close door design with a stay open feature.

■ **COMPLETE INTERIOR LIGHTING**

Strategically placed, safely shielded fluorescent light ensures that all of your products will be adequately illuminated for maximum display effect.

■ **ENGINEERED FOR ENERGY SAVINGS**

Turbo Air refrigerators keep your products cold without costing you a fortune in electricity. Our compressors are highly efficient and quiet. Refrigerator walls are insulated with a high-density, closed cell, expanded polyurethane foam which offers a high insulation factor. Even doors have a special film between the layers of glass to keep the cold in and the heat out. All of these features add up to a quicker pull-down time, less compressor run time and greater savings on energy!

■ **REFRIGERATED GLASS DOOR MERCHANDISER**

Turbo Air's freshly refined design maximizes the display effect.

* A certificated member of NMSDC

* **CEC. California Energy Commission Certificated**

* **MEA. City of New York Building Department Approved**

■ **FULLY ADJUSTABLE WIRE SHELVES**

Our fully adjustable wire shelves are made from heavy gauge metal wire, specially treated and layered with a non-corrosive coating.

■ **SIMPLE MAINTENANCE**

All refrigeration systems are on slide out rails to make maintenance and service easier. Our internal systems are positioned for easy access and repair.

■ **STANDARD BACKGUARD IMPROVES AIRFLOW**

■ **OPTION**

- Casters (2" plate mount caster set only) are available.
- Customized graphics & colors available in quantity
- Gravity feed merchandising racks

■ **HOLDS 33°F ~ 38°F**

■ **FOAMED WITH POLYURETHANE, HIGH-DENSITY CELL INSULATION (CFC FREE)**

* Actual shelf organizer may differ in appearance than above picture.



LISTED COMMERCIAL REFRIGERATOR AND/OR FREEZER 43BK



CEC
MEA

Model	Swing Door	CU./FT.	#of Shelves	HP	AMPS	Weight	L D H
TGM-5R	1	5	3	1/10	22	75	18.9 x 23.6 x 33.7
TGM-11RV	1	11	4	1/4	5.4	137	23.6 x 24.8 x 63.7
TGM-14RV	1	14	4	1/4	6.3	168	23.6 x 26.1 x 73.9
TGM-22RV	1	22	4	1/4	7.6	225	28.7 x 30.2 x 79.7

Glass Door Merchandisers

CABINET INTERIOR/EXTERIOR SPECIFICATIONS

MODEL	TGM-5R	TGM-11RV	TGM-14RV	TGM-22RV
Exterior Dimension(LxDxH)	18.9x23.6x33.7	23.6x24.8x63.8	23.6x26.1x73.6	28.8x30.3x79.9
Interior Dimension(in)	16.2x17.0x29.2	18.9x19.7x44.7	19.0x19.9x57.5	24.1x23.6x62.1
Compressor	1/10HP	1/4HP	1/4HP	1/4HP
Power	115V/60Hz	115V/60Hz	115V/60Hz	115V/60Hz
Amp	2.2 A	5.4 A	6.3 A	7.6 A
Power Cord Length	6.4 ft	5.5 ft	5.0 ft	5.0 ft
Plug-In Installation	NEMA 5-15P	NEMA 5-15P	NEMA 5-15P	NEMA 5-15P
Net Weight	75lbs	137lbs	168lbs	225lbs
Weight After Packing	79.4lbs	174.2lbs	195.5lbs	264.6lbs
Shelves	3EA	4EA	4EA	4EA
Shelf size	A:16.1x14.3 B:16.1x15.7 C:16.1x9.1	20.2x14.5	A:20.4x16.9 B:19.5x16.9	25.5x19.4
Bottle Capacity	Full Load Line	114	150 120	280

Swing Door Models



*Design and specifications subject to change without notice.

(unit : inch)

TGM-5R PLAN VIEW

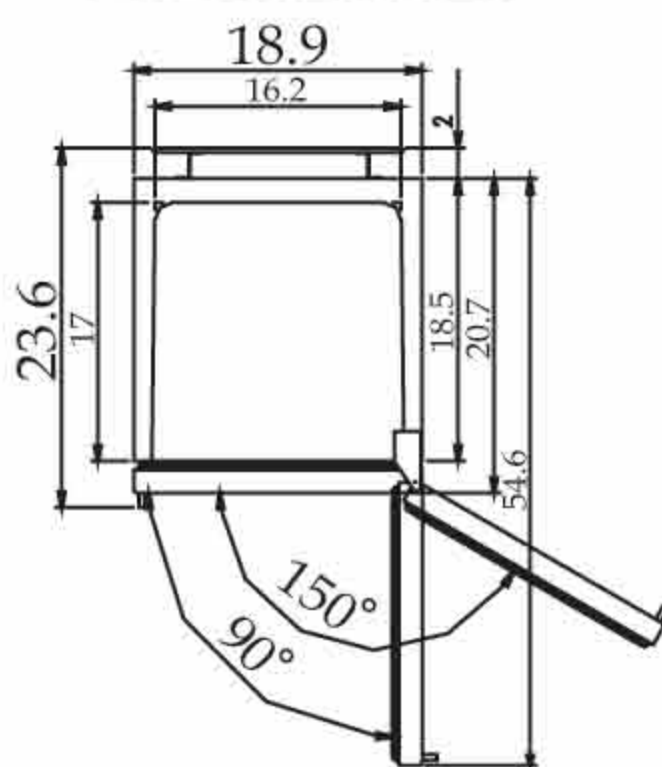

TGM-11RV PLAN VIEW

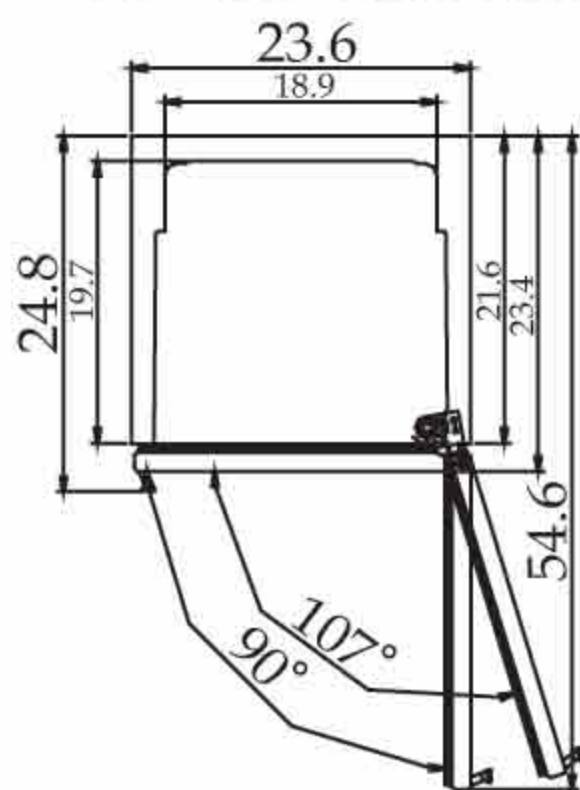

TGM-14RV PLAN VIEW

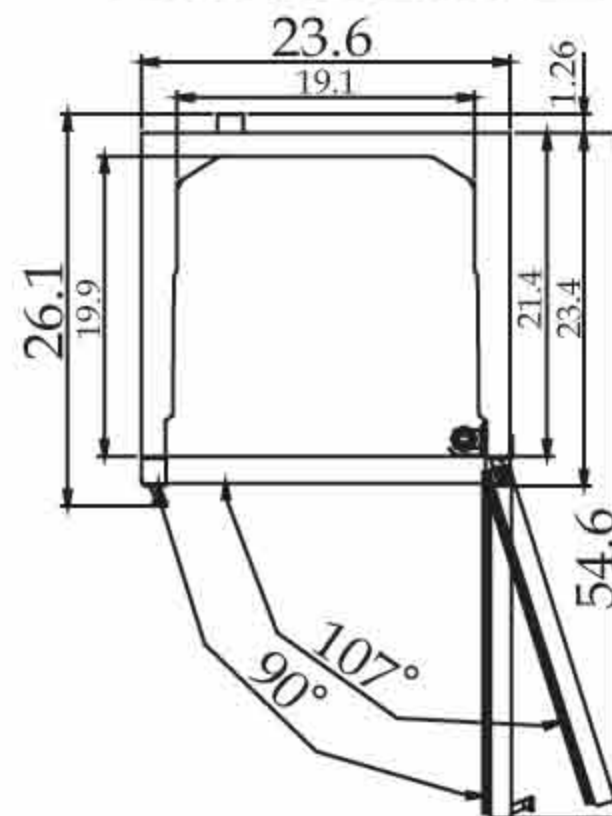

TGM-22RV PLAN VIEW

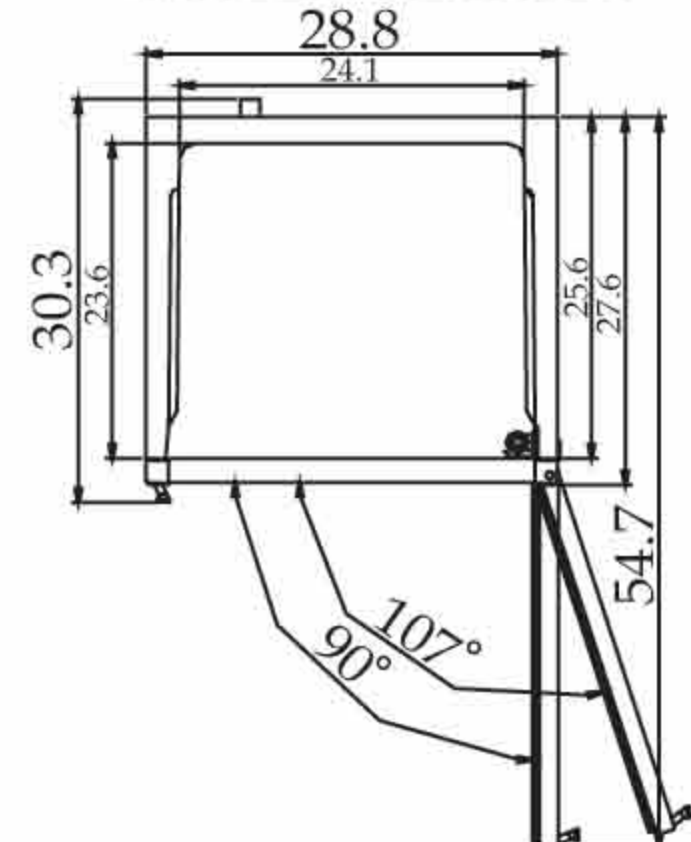

(unit : inch)

TGM-5R SIDE VIEW

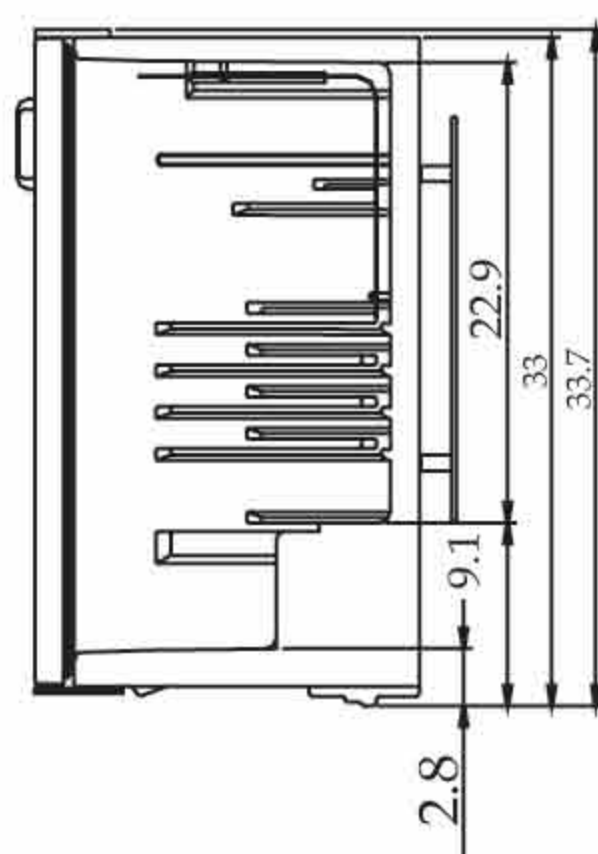

TGM-11RV SIDE VIEW

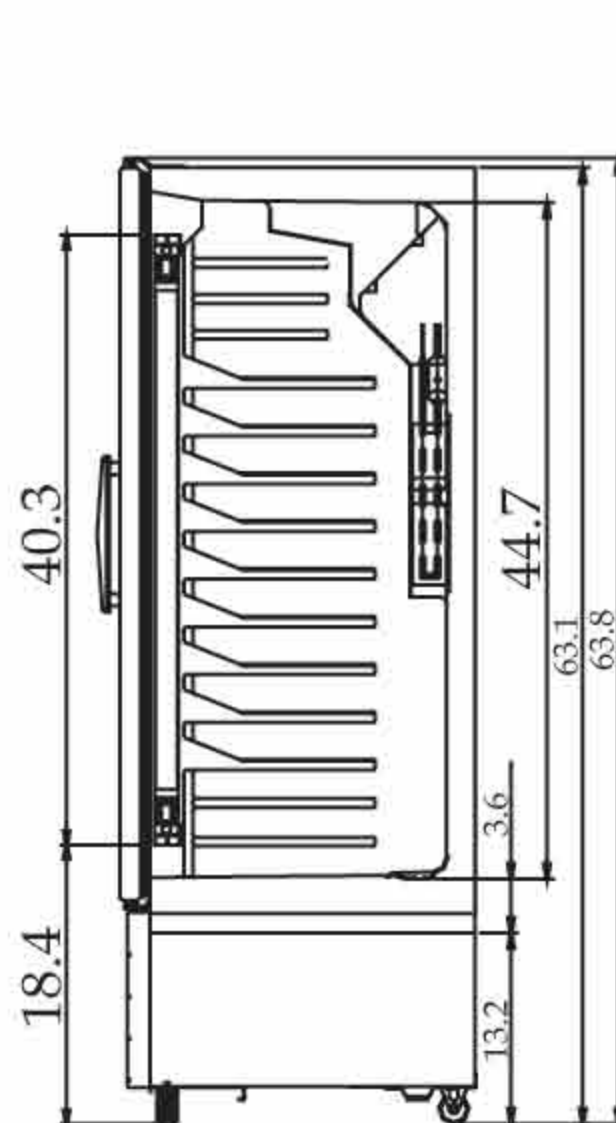

TGM-14RV SIDE VIEW

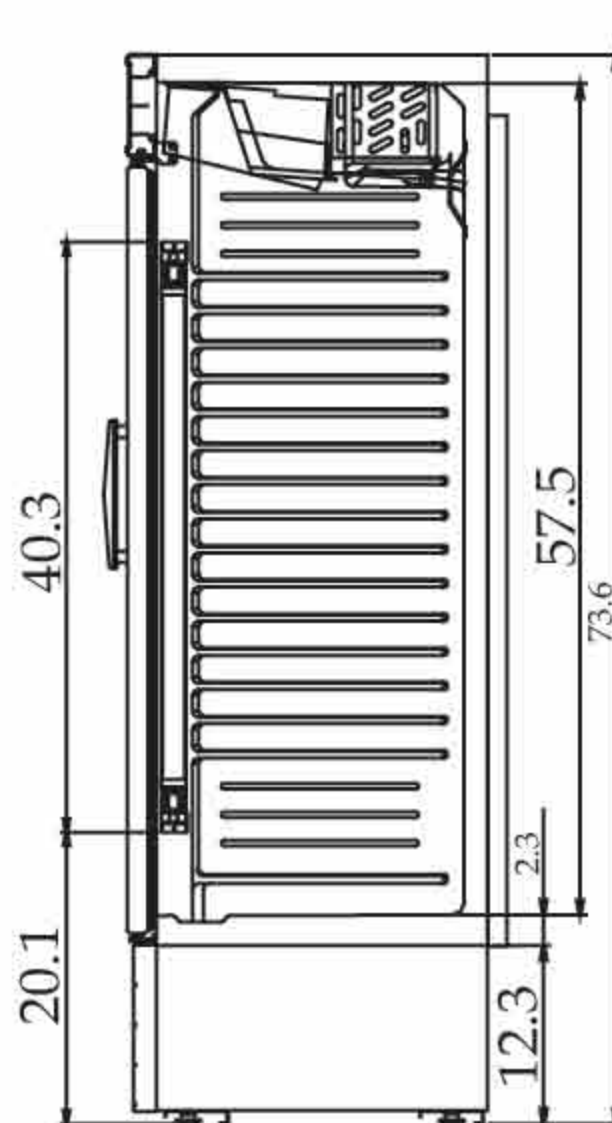

TGM-22RV SIDE VIEW

