



||| a Standex company

Item \_\_\_\_\_

# WALL DISPLAY NON-REFRIG. SELF-SERVE BAKERY CASE MODEL WDC-42



*Generate increased impulse sales with maximum product exposure.*

## STANDARD FEATURES

- Tempered self-closing full view front service doors.
- Glass ends and top.
- All-welded base and frame construction with a choice of six standard laminates on base and counter top. Satin finish stainless steel trim. Other color laminates optional.
- Four adjustable white epoxy coated slanted wire shelves.
- Mirrored back panel.
- Base storage area with solid sliding doors.
- Bag bin with three dividers.
- Counter top with tissue holder (5 3/4" x 6 1/2" x 2 1/2").
- Sloped front providing high visual product display.
- Cord and plug.

# WALL DISPLAY

## NON-REFRIGERATED SELF-SERVE BAKERY CASE

### OPTIONAL ACCESSORIES:

- \* Special Base Finish
- \* Vertical Lights
- \* Mirrored Ends
- \* Rear Sliding Doors
- \* Casters (Cord and Plug Included)

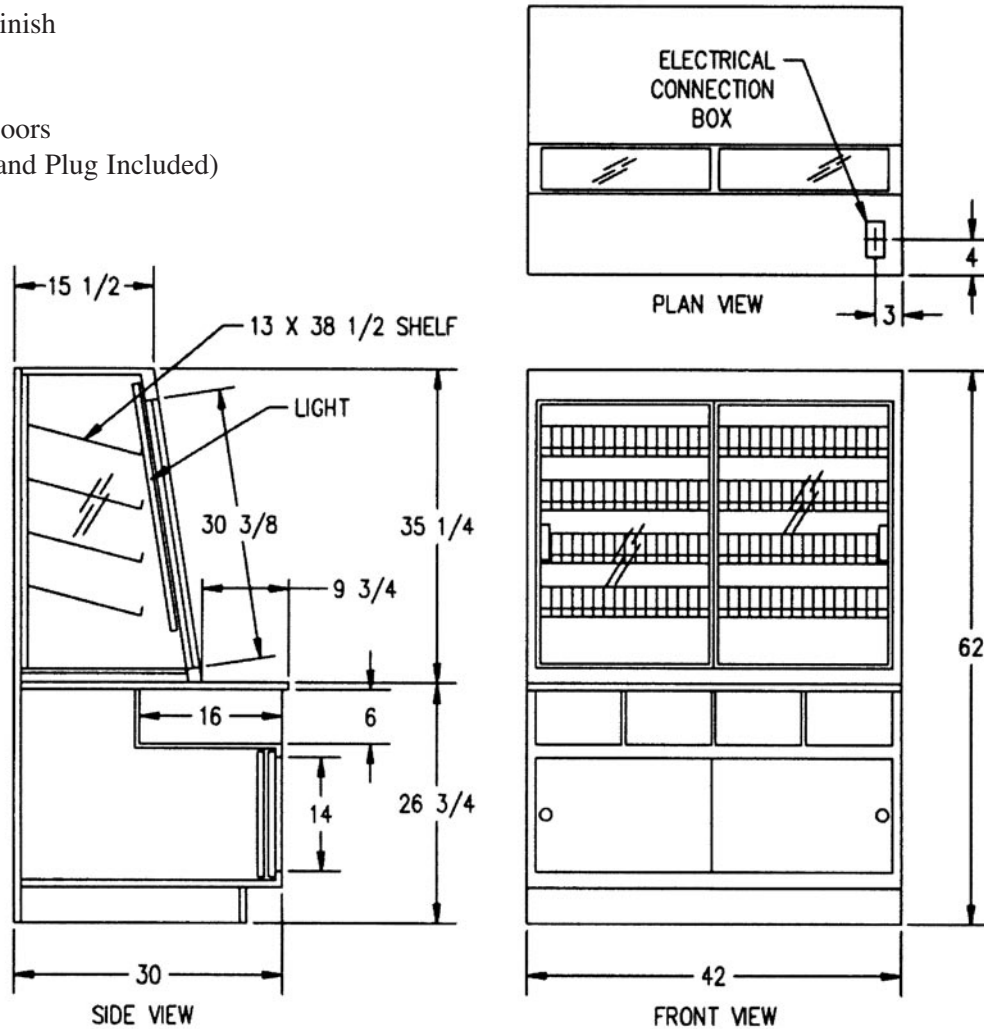

### SPECIFICATIONS:

Model	Dimensions			Shipping Weight (lbs)	Capacity (Bakery Pans)
	L	W	H		
WCD-42	42"	30"	62"	350	10 (12" x 18")

\*\* Electrical requirement for optional lights - 120/60/1 - 2 AMPS.

- Due to continuing engineering improvements, specifications are subject to change without notice.



**Look to Federal for Innovative Merchandising**



**a Standex company**

**Federal Industries**  
**A Standex Company**  
**215 Federal Avenue**  
**Belleville WI 53508-0290**  
**Phone: 800-356-4206**  
**Fax: 608-424-3234**  
**Email: [geninfo@federalind.com](mailto:geninfo@federalind.com)**  
**Web Site: [www.federalind.com](http://www.federalind.com)**